

Humidity sensors - FG80Exi

and combined

Humidity-temperature sensors - TFG80Exi

with "Polyga™" humidity measuring element for the measurement of relative air humidity and temperature - for rooms and air channels.

Remark: the sensor is only to be used in connection with approved safety barriers and measuring transmitters or adequate equipment for ex-applications. for circuit with intrinsic safety only.

Model overview

passive sensors

FG80Exi Humidity Sensor
with resistance output
0...1000 ohm or 100...138,5 ohm
for circuit with intrinsic safety

TFG80Exi Humidity-temperature Sensor
with humidity resistance output
0...1000 ohm or 100...138,5 ohm
with Pt100 temperature measuring element
for circuit with intrinsic safety

Description of the sensor :

The "Polyga™" humidity measuring element consists of several synthetic fabric bands each with 90 individual fibres with a diameter of 3 µm each. In their untreated state, the synthetic fibres are not hygroscopic - their hygroscopic properties are acquired by means of a special process which allows the synthetic fibres to absorb moisture. The molecular structure of the individual fibres is arranged lengthways. When water is absorbed, the molecular chains alter, the outward result being a change in length. A loss of water has a converse effect on the fibre. If the fibre is in equilibrium with the air humidity, there is neither absorption nor a loss of water. The length at this point serves as a gauge for the relative humidity.

If the measuring element is exposed to an air humidity of 100%rh, a film of water forms on the surface of the element (dew point). The physical effect is one as if the measuring element had been immersed in water. The measuring element is saturated. An ideal fixed point is thus attained for adjusting or controlling the sensors. The measuring element is waterresistant. Once administered to the Galltec measuring element, the hygroscopic properties remain stable, the sensitivity remaining until it becomes destroyed by extraneous influences. Regeneration as with fine-measuring elements is not necessary, but does not cause any harm.

This information is based on current knowledge and is intended to provide details of our products and their possible applications. It does not, therefore, act as a guarantee of specific properties of the products described or of their suitability for a particular application. It is our experience that the equipment may be used across a broad spectrum of applications under the most varied conditions and loads. We cannot appraise every individual case. Purchasers and/or users are responsible for checking the equipment for suitability for any particular application. Any existing industrial rights of protection must be observed. The perfect quality of our products is guaranteed under our General Conditions of Sale.
Issue : June 1996 FG80_E. This issue supersedes all previous technical leaflets.

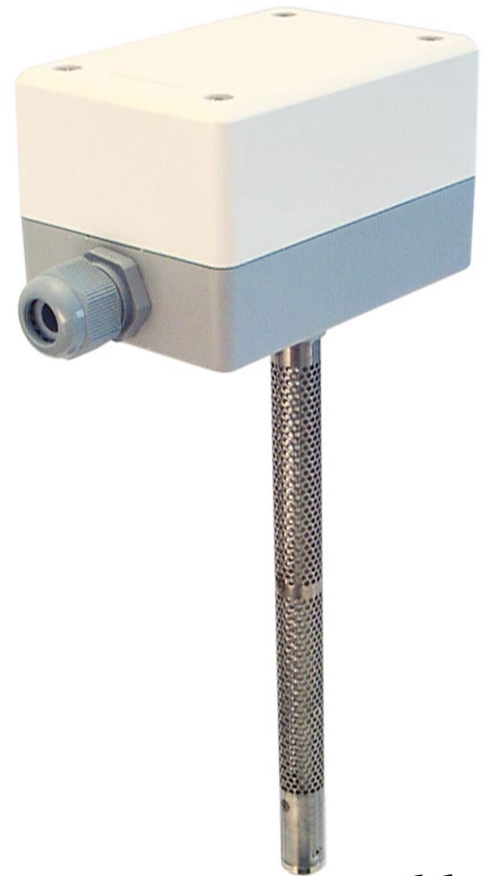

FG80...
TFG80...

Design of the sensor

The expanding action (predominantly lengthways) of the fibres is picked up by means of a potentiometer and converted

The fan-shaped measuring element is protected by a perforated sensor tube..... The sensors are designed for pressureless systems. The unit should be installed in a location where condensation cannot enter into the housing. A preferred position would be "sensor vertically down" or "sensor horizontal". In these positions, a cover plate with a 0.8 mm diameter hole will prevent water from entering.

The TFG80Exi sensors have built-in Pt100 temperature sensors for simultaneous measurement of temperature

Ageing

In order to maintain their long-term stability, it is important that the measuring elements undergo a special ageing process, details of which cannot be given here.

Reaction of the sensor

Due to the law of diffusion, there is a time delay before the fibres are saturated during water absorption. This is a decisive factor when determining the reaction time. Thus, for one individual fibre with a diameter of 3 µm, a short saturation time (several seconds) can be measured. Empirical investigations show that bundled or woven fibres, as are used here in the Galltec sensor, give rise to a longer period prior to saturation. This is because the individual fibres impede each other during water absorption and/or water loss, and the ensuing humidity does not register until later. Measurements have shown that, at a wind speed of 2m / sec. the half-life period is 1.2 mins. This represents an effective period of approx. 30 - 40 mins.

Half-life period

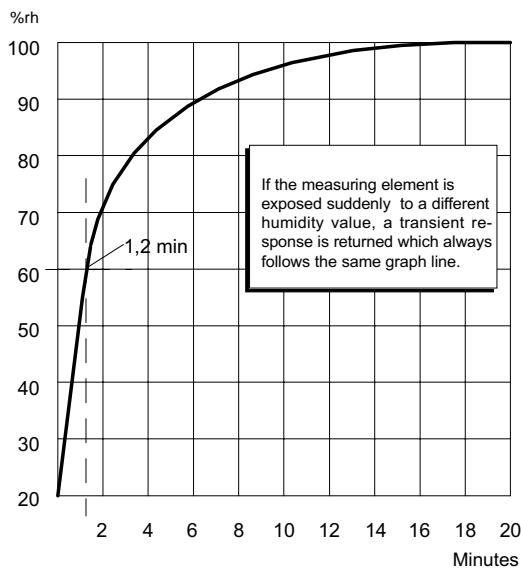

Transient response of the measuring element between 20 and 100% rh.

Thermal behaviour

The temperature coefficient of the Galltec element is not linear. In the high humidity range the temperature error is very small, whilst it rises more sharply in the low humidity range.

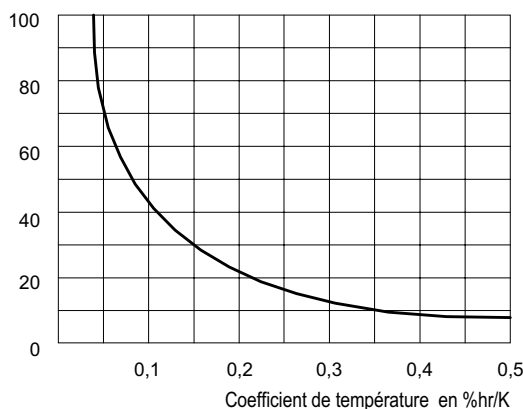

80° C is given as the maximum temperature value. Higher temperatures can only be tolerated for a short period of time. The eventual result is a change in the molecular structure which causes a constant error. The maximum temperature of 80° C only applies, however, if no harmful substances (acids, solvents etc.) are present in the medium.

Technical data

Physical data

humidity	measuring range	0...100%rh
	measuring accuracy	
	... >40%rh	±2.5%rh
	... <40%rh ... according to tolerance diagram	
	working range	30...100%rh
temperature	working range	-20...+40°C
	measuring accuracy	±0.5°C
	measuring medium	air, pressureless, non-corrosive
	permissible ambient temperature	-20...40°C
	temperature class	T6
	mean temperature coefficient	-0.1%/K ref. to 20°C and 50%rh
	adjustment	at average air pressure 430m NN
	permissible air speed	8m/sec
	with protective gauze (order no. 20.014)	15m/sec
	half-life period at v=2m/sec	1.2min
	sensor length ; sensor material	220mm; high-grade steel
	fixing	slots in housing base for channel mounting
	(order no. 20.009)	console for wall mounting
	mounting position	sensor vertically downwards, or horizontal
	connecting terminals	for conductor cross sections 0.5mm ²
	cable connection	by metal twist nipple Pg 13.5 resp. M20
	electromagnetic compatibility	
	resistance to interference	EN 50 082-2
	interference emission	EN 50 081-2
	housing	ABS light grey
	protective system	IP64
	weight	ca 0.4 kg

Electrical data for passive sensors

Humidity Output 1	0...1000 ohm linear 2-wire
permissible load	100 mW
max. voltage	9.0 V
max. current	25 mA
max. inductance	< 100 µH
max. capacity	< 10 pF
insulation resistance	10 Mohm

Temperature Output 2 (TFG80Exi)	Pt100 ref. DIN 43760
permissible load for air 1m/sec and t=0.1K	2 mA

"modification rights reserved"

Type	Humidity		Temperature		Operating voltage	Conductor system	Order No.
	Measuring range 1	Output 1	Measuring range 2	Output 2			

Overview of passive sensors

FG80Exi	0...100%rh	0...1000 Ohm or 100...138,5 Ohm			max 9V	2-pin	
TFG80Exi	0...100%rh	0...1000 Ohm or 100...138,5 Ohm	Pt100	passive	max 9V	2-pin	

Humidity and tolerance diagram

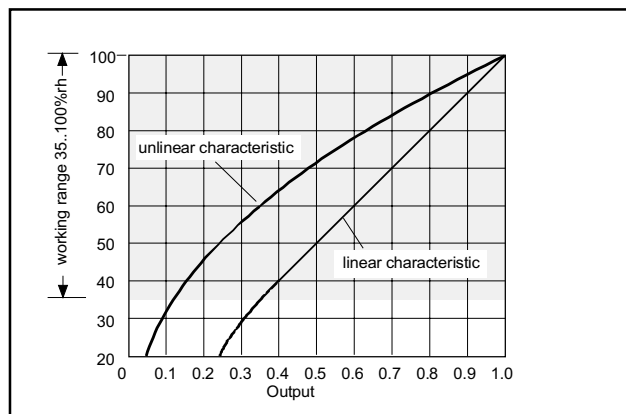

Connection diagram for passive sensors with resistance output

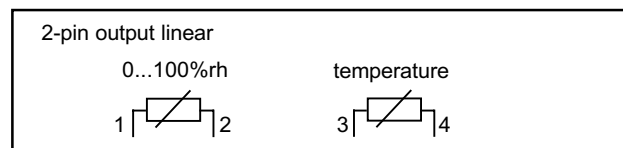

Important The air's capacity to absorb water is influenced among other factors by the temperature. This is a physical law (identified in the *hx* diagram of Mollier). The higher the air temperature, the larger the amount of steam that can be absorbed up to saturation point (100%rh). If a sensor is calibrated under varying air temperature conditions, the result is an irregular, unhomogenous measuring medium which automatically gives calibration errors. The table below shows the influence of the air temperature on air humidity. If, for example, calibration occurs at an air temperature of 20°C and 50%rh and a varying temperature range of only +/-1 °K, this results in a variation in humidity of the measuring medium (air) of +/-3.2%rh.

	10°C	20°C	30°C	50°C
10%rh	+/-0,7%rh	+/-0,6%rh	+/-0,6%rh	+/-0,5%rh
50%rh	+/-3,5%rh	+/-3,2%rh	+/-3,0%rh	+/-2,6%rh
90%rh	+/-6,3%rh	+/-5,7%rh	+/-5,4%rh	+/-4,6%rh

Physical influence of air temperature on air humidity

Calibration

For equipment with Galltec sensors to operate correctly, a room temperature of 23°C and 50%rh should be set. If, however, a further adjustment is necessary, the following procedure should be adhered to :

- Ensure that the ambient humidity as well as the ambient temperature are constant.
- If possible, use a psychrometer for testing (do not use testing equipment with capacitive sensors).
- Leave the equipment to be tested for a *minimum of 1 hour under constant test conditions*.
- All Galltec sensors are equipped with an adjustment facility. In most cases this involves an adjuster screw fixed with screw securing lacquer. When the lacquer is removed the screw can be adjusted. After calibration, the adjuster screw should again be secured.

Maintenance - Instructions for use - Effect of pollutants

The measuring element is maintenance free when the surrounding air is clean. Agents that are corrosive and contain solvents, depending upon the type and concentration of the agent, can result in faulty measurements and cause the measuring element to break down. Direct sunlight should be avoided. Substances deposited on the sensor are damaging as they eventually form a water-repellent film (this applies to all humidity sensors with hygroscopic measuring elements). Such substances are resin aerosols, lacquer aerosols, smoke deposits etc. The water-resistant property of the Galltec sensors allows for cleaning using water. Solvents cannot be used for this purpose. A light-duty detergent is recommended. Any detergent residue should, however, always be thoroughly washed out. A special process ensures that Galltec sensors have good long-term stability. Regeneration is not necessary, but is also not harmful.

WARNING The guarantee is no longer valid if the interior of the measuring element has been accessed.

Dimensions diagram

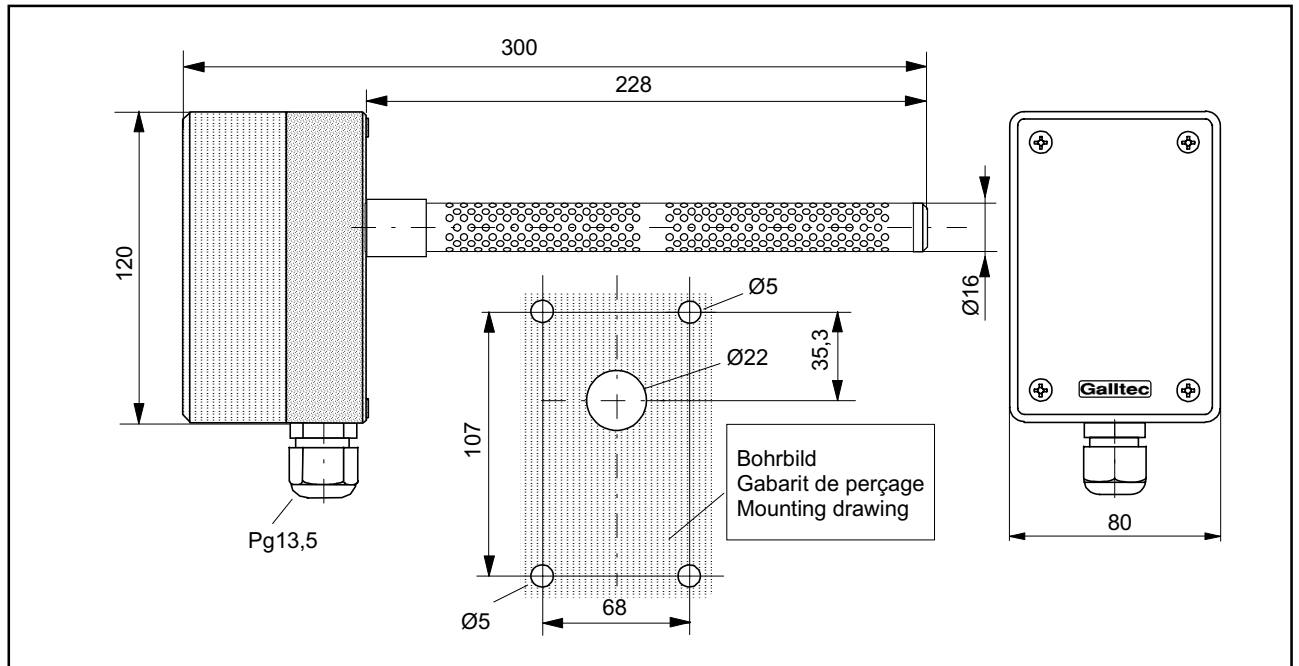

Accessories

