

POWER CONTROLLER

THW-3 SERIES Power Controller Three Phase Thyristor Unit



High performance power controller with powerful functions

1 Easy and accurate setting

Three phase power controller has an LED display to show set values and input signals, and front keys for easy setting and monitoring. Setting can also be made with an external setting unit (variable resistor).

2 Powerful control functions

The THW Series is available with constant current control, constant power control or constant voltage control. It makes the THW Series suitable for any application with three phase power control.



3 Works against a rapid response

With either the ramp-up (soft-start) or ramp-down (soft-down) set to zero, the THV quickly responds to input changes, and can be used in applications like RTP (Rapid Thermal Process).

4 Useful standard functions

Gradient setting, ramp-up (soft-start), ramp-down (soft-down) and high/low output limiters are supplied as standard.

5 Auto-detecting power frequency

The THW automatically selects power supply frequency 50 or 60Hz.

6 Three types of control modes are selectable

Phase control

The wave form of the load power is switched at a desired phase angle θ to provide smooth control.



Zero-cross control (Continuous proportional)

Power is switched on and off when the supply voltage is at 0V. This system suppresses high frequency noise inherent to phase control.



Zero-cross control (Input synchronization system)

Supply voltage is switched on and off according to the voltage pulse or contact signals from a controller.

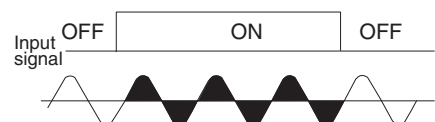

Standard Functions

Gradient setting

The relation between the setting input and the output voltage can be set. Gradient setting is possible via front keys or an external setter. Control characteristics may vary with the setting as follows.

1. Auto setting input X Internal gradient setting X External gradient setting
2. Auto setting input X Internal gradient setting
3. Manual setting X Internal gradient setting X External gradient setting

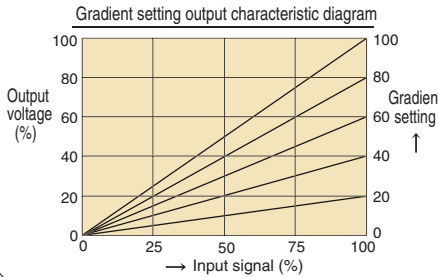

Ramp function (Soft-start & Soft-down)

Even if setting input changes abruptly, output changes slowly to suppress inrush current. Ramp-up (Start-up) and ramp down (Start-Down) time can be set in the range of 0.1 to 99.9 sec via front keys.

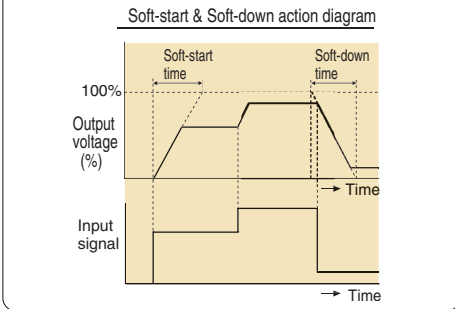

Output limiter (High & Low)

Output highest and lowest values can be set via front keys.

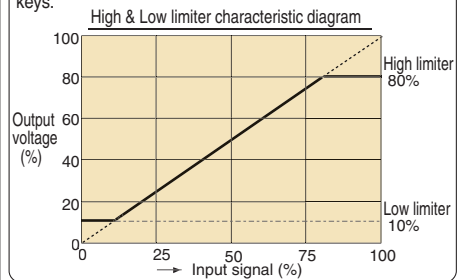

Base-up setting (Output bias)

Output bias can be set via front keys. (Base-up setting is valid when output limiter low is set to 0.0)

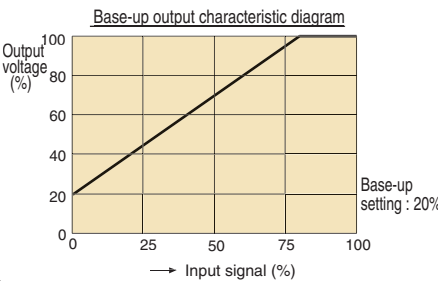

Three types of output modes

When phase control is selected for linear load (R: resistor), output mode can be selected among Proportional phase angle to input, proportional voltage to input, and proportional square voltage (electric power) to input.

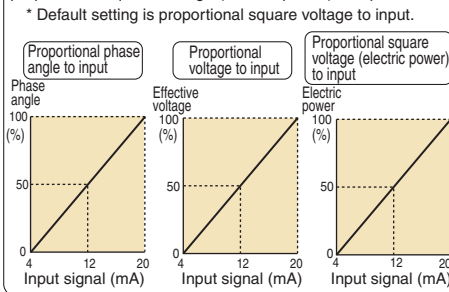

Output limiter High at start-up

This function limits the highest output for the period of a preset time after power-ON and control mode change from Stop to Run. It makes the THW Series suitable for heaters which cause rush current flow, such as Halogen lamp, Tungsten, Platinum, and Molybdenum heaters.

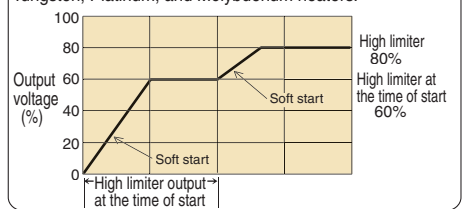

Event input and alarm function

The contact input can be configured to Run/Stop, Auto/Manual or alarm interlock reset. The alarm types are reverse phase detection, power frequency abnormal, and FAIL. Alarm output will go on, when any of them goes in alarm status. Optional heater break alarm and over-current alarm can be also configured as an output (alarm logic selection).

Optional Functions

Constant current control (For phase control only)

This function maintains the output current constant when a load or a power supply fluctuates. It makes the THW Series suitable for heaters of which resistance greatly changes by temperature change, such as Platinum, Molybdenum, Tungsten, and Tantalum heaters.

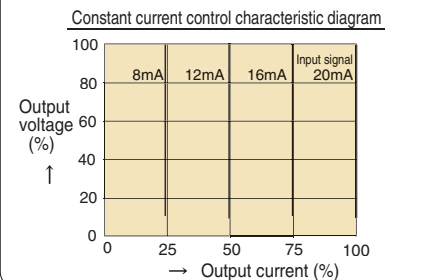

Constant power control (For phase control only)

This function controls the output to make its effective value power proportional to the input. It makes the THW Series suitable for heaters of which resistance gradually increases by temperature or time, such as silicon carbide type heater. This function controls its effective value power at 50% of the rating shown in the diagram below.

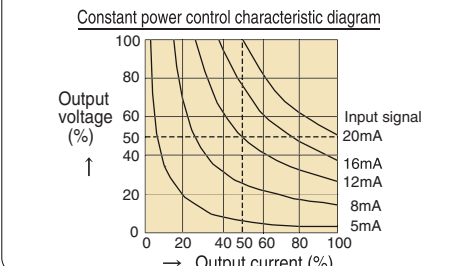

Constant voltage control (For phase control only)

This function maintains the output voltage constant when a load or a power supply fluctuates.

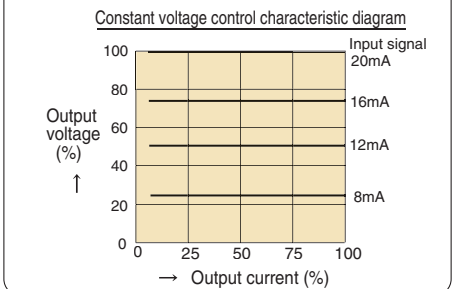

Load current limiter (For phase control only)

This function limits the load current value to the heater. The setting range is 30 to 100% of the rated current.

(Note) If the load has a large inrush current, use soft-start function along with this function to suppress the inrush current. This function alone can not prevent the inrush current.

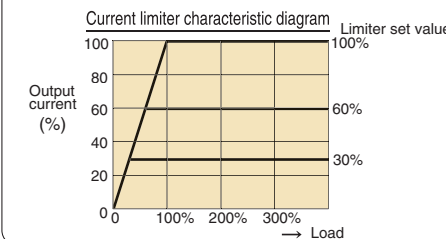

Heater break alarm

This function measures load current and compares it with a heater break alarm set value. Alarm will be activated if the load current goes into alarm ranges. Maximum two alarm set points can be set for the heater break alarm, which could be used for heater-deterioration alarm and heater-break alarm.

(Note) For phase control, heater break alarm does not work when the load current is less than 15% of maximum load current.

Over-current alarm

The alarm goes on when the load current exceeds 120% of the rated current.

Fuse break alarm

The alarm goes on when a fast blown fuse is blown. The fuse with alarm output function must be used to use this function.

Specifications

Max. load current : 20A, 30A, 45A, 60A, 80A, 100A AC
 Control method : Phase control/ Zero-cross control (Selectable)
 Applicable load : Phase control : Linearity (R:Resistor) load, Control of primary side of a transformer (magnetic field density 8,000 gauss or less)
 Zero-cross control : Linearity (R:Resistor) load

Input signal : Group 1 (Field-programmable within Group)
 Current input 4 to 20mA DC (Input impedance : 100Ω)
 Current input 0 to 20mA DC (Input impedance : 100Ω)
 Voltage input 0 to 5V DC (Input impedance : 30kΩ)
 Voltage input 1 to 5V DC (Input impedance : 30kΩ)
 Voltage pulse input 0/12V DC (Input impedance : 30kΩ)
 Non-voltage contact input
 Group 2 (Field-programmable within Group)
 Voltage input 0 to 10V DC (Input impedance : 68kΩ)
 Voltage pulse input 0/12V DC (Input impedance : 68kΩ)
 Voltage pulse input 0/24V DC (Input impedance : 68kΩ)
 Non-voltage contact input

Min. load current : 1A
 Output voltage range : 0 to 98% of rated voltage
 Power supply voltage : a) 90 to 264V AC (Including power supply voltage variation)
 Rating : 200 to 240V AC
 b) 360 to 484V (Including power supply voltage variation)
 Rating : 400 to 440V AC
 * Power supply voltage for control circuit voltage is 180 to 264VAC. A step-down transformer is supplied with the main unit (Including power supply voltage variation)
 Rating : 200 to 240V AC

Power consumption : Less than 17VA (200V type), Less than 21VA (400V type)
 Power frequency : 50/60Hz (Automatic detection)
 Allowable power : 50±1Hz, 60±1Hz (Performance guarantee range)
 frequency variation : 45 to 54.9Hz (50Hz), 55 to 64.9Hz (60Hz)
 (Operating guarantee range)

Output setting range : Gradient setting : 0.0 to 100%
 [Front key or external setting unit]
 Output limiter (High) : 0.0 to 100.0% [Front key]
 Output limiter (Low) : 0.0 to 100.0% [Front key]
 Output limiter at start-up (High) : 0.0 to 100.0% [Front key]
 Output limiter at start-up (Low) : 0.0 to 100.0% [Front key]
 Base-up setting (Output bias) : 0.0 to 100.0% [Front key]
 Manual setting : 0.0 to 100%
 [Front key or external setting unit]

Output mode : When phase control is selected for linearity load (R: resistor), output mode can be selected from Proportional phase angle to input, proportional voltage to input, and proportional square voltage (electric power) to input.

Cooling method : Natural convection
 Operating ambient temperature : Performance guarantee range: 0 to +40°C
 Operation guarantee range: -15 to +55°C

Operating ambient humidity : 5 to 95%RH (Non-condensing)
 Absolute humidity : MAX.W.C 29.3g/m³ dry air at 101.3kPa

Dielectric voltage : Between main circuit terminals, power terminals and heat sink 2000V AC for one minute.

Insulation resistance: Between main circuit terminals, power terminals and heat sink 20MΩ or more (500V DC)

Self-diagnostic function : Check item :
 Board check, EEPROM check
 Adjustment data check, Set value range check
 Action at abnormality :
 FAIL lamp ON, Thyristor output OFF
 (The alarm output can be output from the alarm terminals.)

Mounting method : Vertical mounting
 Weight : Approx. 5.8kg (20 to 60A, 200V),
 Approx. 10.3kg (20 to 60A, 400V),
 Approx. 13.6kg (80A, 100A, 200V and 400V)

Standard functions

- Digital input (DI) : 3 points, Non-voltage contact input RUN/STOP, Auto/Manual, Alarm interlock reset
- Gradient setting (External setting unit is optional)
- Soft-up/Soft-down : 0.0 to 99.9sec
- Alarm output : 2 points
 Open collector output, 24V DC, Max.100mA
 Energized/De-energized is selectable.
 Output logic selection function
 1. Heater break alarm *1
 2. Thyristor break alarm *1
 3. OR logic of heater break alarm *1 and thyristor break alarm *1
 4. OR logic of FAIL, power frequency abnormal, reverse phase detection, over-current alarm *1, fuse break down *1
 5. OR logic of all alarm
 *1: Optional alarm type

Option function

- ON/OFF control (External setting units are optional)
- Heater break alarm
 Current measuring accuracy :
 ±2A (20A, 30A type)
 ±10% of Max. load current
 (45A, 60A, 80A, 100A type)
 Number of alarm delay times : 0 to 99 times
- Load current limiter
 Setting range : 0 to 22.0A (20A type)
 0 to 33.0A (30A type)
 0 to 50A (45A type)
 0 to 66A (60A type)
 0 to 88A (80A type)
 0 to 110A (100A type)

Table of Stability

Function	Operating condition	Stability
Constant voltage variation	Power supply variation : Within ±10%	Within ±2% of full scale
	Load variation : 2 times	
Constant current variation	Power supply variation : Within ±10%	Within ±2% of full scale
	Load variation : 2 times	
Constant power variation	Power supply variation : Within ±10%	Within ±4% of full scale
	Load variation : 2 times	

Table of internal calorific value

Max.load current (A)	20	30	45	60	80	100
Internal calorific value (W)	82	118	172	226	298	370

• Temperature characteristics of load current

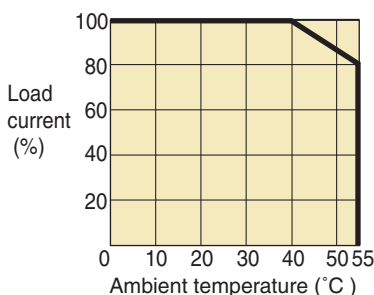

Table of Output Setting Methods

The THW has three output setting methods; input signal from a controller, external manual setting from a setting unit, and internal manual setting via front keys. Which Output setting method is used is decided by a combination of external contact input status and a parameter of external contact input action selection via front keys.

External contact input status	Close	Open
External contact action selection		
Internal manual setting via front keys	Internal manual setting	Internal manual setting
Internal manual setting via front keys / Input signal	Internal manual setting	Input signal from controller
External manual setting / Input signal	External manual setting	Input signal from controller

* External contact is open when a connector is not used.

● Model and Suffix Code

Specifications	Model and Suffix Code												
Type	Three Phase Thyristor Unit	THW-3			<input type="checkbox"/>	PZ	<input type="checkbox"/>	-	<input type="checkbox"/>	* <input type="checkbox"/>	<input type="checkbox"/>	N	<input type="checkbox"/>
Power supply *1	200 to 240V AC 400 to 440V AC	2											
Control method	Phase control/Zero-cross control (programmable, default: phase control)	4											
Max. load current	20A AC											
	30A AC											
	45A AC											
	60A AC											
	80A AC											
	100A AC											
Input signal *2	0 to 5V DC											
	0 to 10V DC											
	1 to 5V DC											
	0 to 20mA DC 4 to 20mA DC											
Output mode *3,*4	Standard (Proportional phase angle • Proportional voltage • Proportional square voltage)											
	Standard + Constant voltage control											
	Standard + Constant voltage control (with heater break alarm and load current limiter)											
	Standard + Constant current control (with heater break alarm and load current limiter)											
Fast-blow fuse *3	No fast-blow fuse											
	With fast-blow fuse (No fuse break alarm output)											
Optional function	With fast-blow fuse (With fuse break alarm output)											
	No optional function											
Accessories *4,*5,*6	Setter (Volume, knob, Scale plate) 1 unit + Connector (Plug)											-1
	Setter (Volume, knob, Scale plate) 2 units + Connector (Plug)											-2
	Connector (Plug)											-9
	Terminal cover (For main circuit terminal)											-A

*1 : When 400 to 440VAC is selected as power supply, a step-down transformer for the THW unit power supply is supplied as standard.

*2 : Input signal is programmable within group.

Group 1 0 to 20mA DC ; 4 to 20mA DC ; 0 to 5V DC ; 1 to 5V DC ; Voltage pulse 0/12V DC ; Non-voltage contact

Group 2 0 to 10V DC ; Voltage pulse 0/12V DC ; Voltage pulse 0/24V DC ; Non-voltage contact

*3: When optional heater break alarm and load current limiter are specified, over-current alarm and thyristor break alarm are also supplied.

*4: When contact input or/and alarm output is required, specify the connector as an accessory.

*5: Setters are for external gradient setting, external manual setting, and external high/low setting for on/off control. Use two units of setter in the following cases;

- When external gradient setting and external manual setting are required.
- High/low setting for on/off control is used.

*6: It is possible to specify more than one accessories by adding suffix code at the end. (Example: -1-9-A)

External Dimensions Unit: mm

○ 200V : 20A, 30A, 45A, 60A

○ 400V : 20A, 30A, 45A, 60A

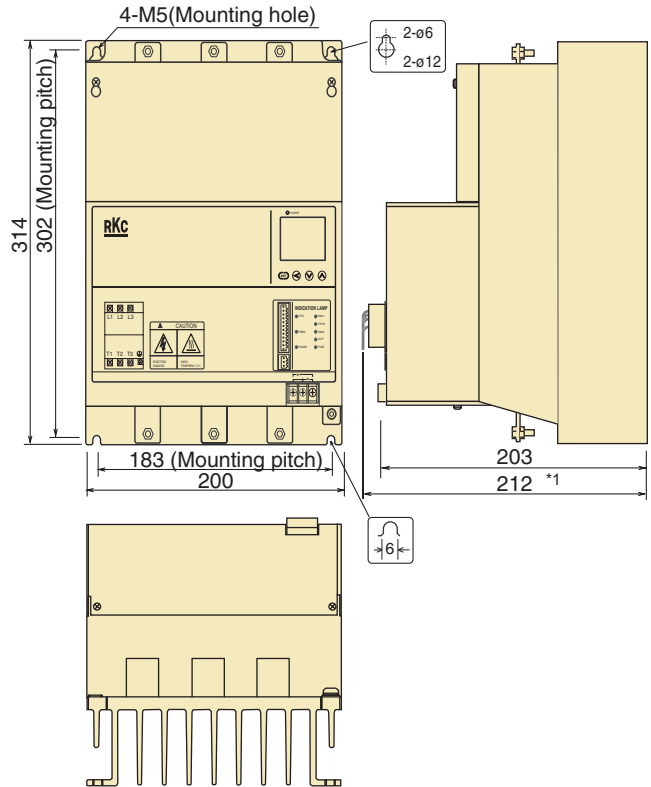
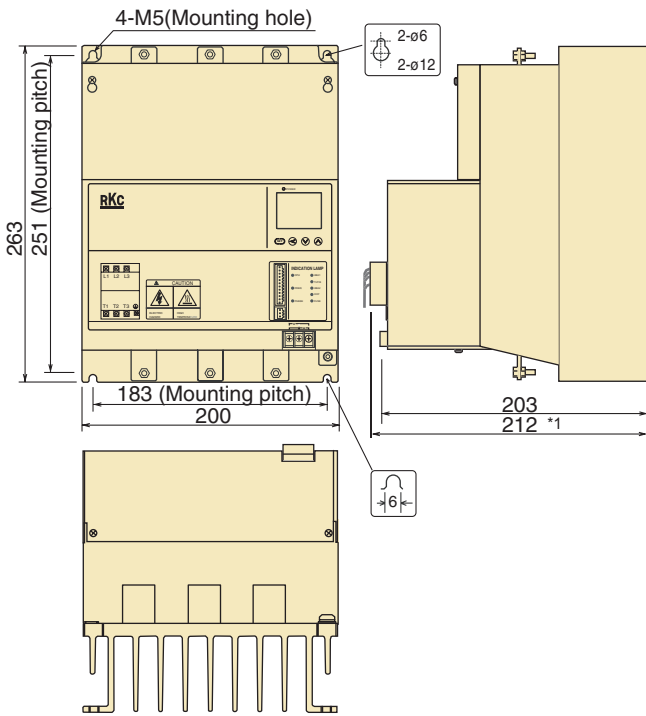

○ 200V : 80A, 100A
400V : 80A, 100A

• Install the instrument as illustrated in the drawing to increase the cooling effect.

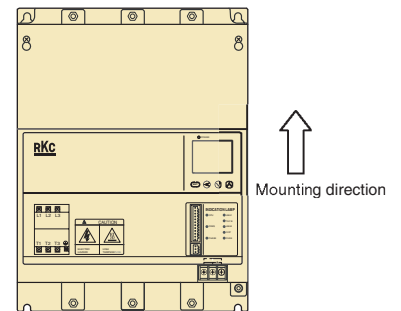
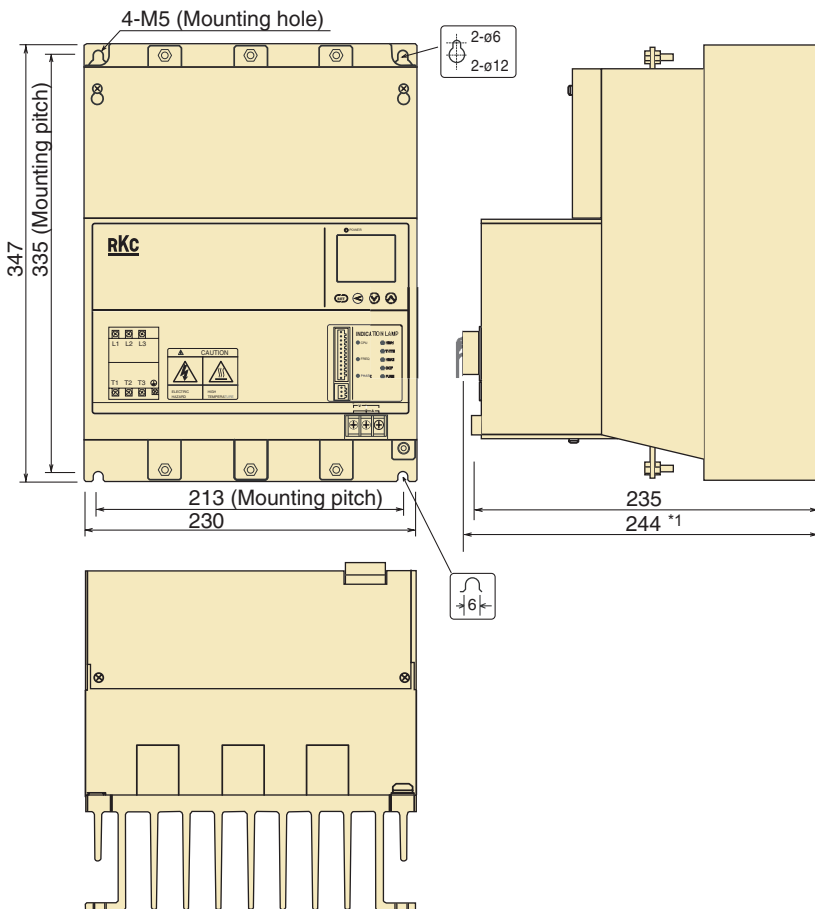

• When multiple units are installed, space between units must satisfy the rules shown in the drawing below.

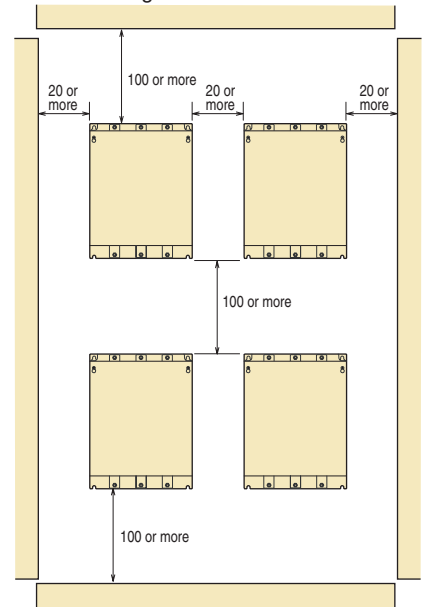

*1 : Length includes that of an optional connector, but space for wiring to connector is not included.

External Wiring

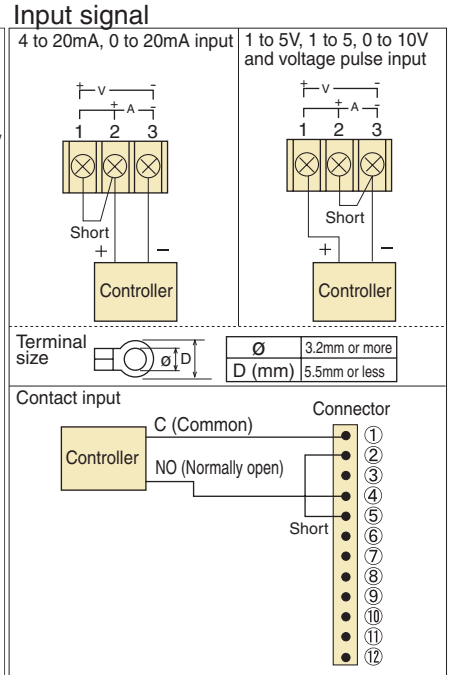
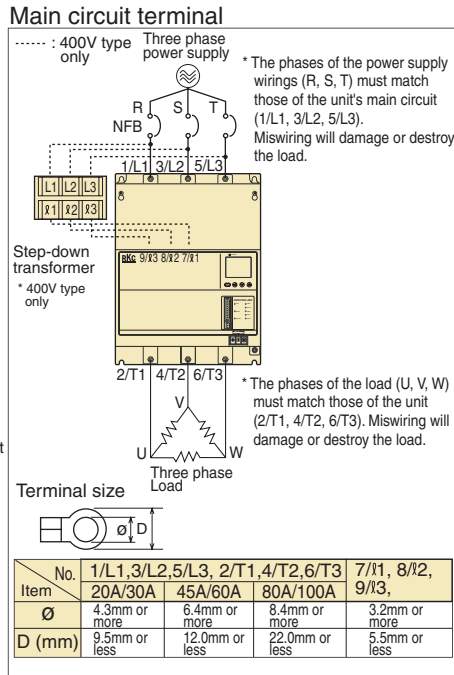
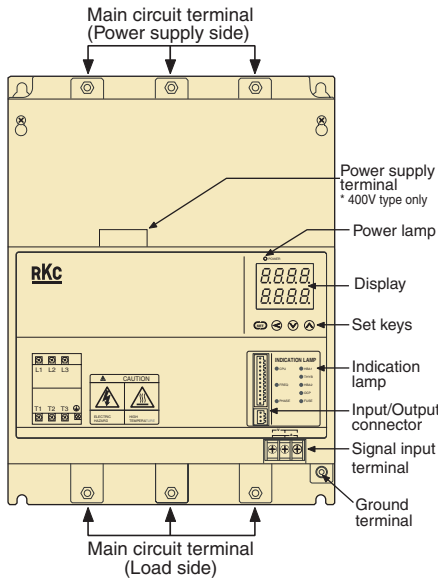

Indication Lamp

INDICATION LAMP

- FAIL
- FREQ
- PHASE
- HBA1
- THY_B
- HBA2
- OCR
- FUSE

Lamp	Contents
FAIL	FAIL(Self-diagnostic abnormality)
FREQ	Power frequency abnormality
PHASE	Reverse phase detection
HBA1	Heater break alarm SV1
THY_B	Thyristor break alarm
HBA2	Heater break alarm SV2
OCR	Over current alarm
FUSE	Fuse break alarm

* Up to two alarm set points can be set for the heater break alarm.
* Fuse break alarm lamp is available when a fast blow fuse with fuse break alarm output is used.

Connector

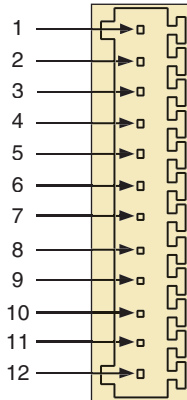

Pin No.	Contents
1	+5V output
2	0V (GND)
3	Gradient setting input (0 to 5V input by gradient setter)
4	Manual setting input (0 to 5V input by manual setter)
5	External contact input (Auto/manual setting selection) Pin No.2 - No.5, Open : Auto setting mode Pin No.2 - No.5, Close : Manual setting mode.
6	External contact input (RUN/STOP selection) Pin No.2 - No.6, Open : Stop mode Pin No.2 - No.6, Close : Run mode.
7	External contact input (Alarm interlock reset) Pin No.2 - No.6, Close : Alarm interlock reset
8	Unused
9	DC24V (+)
10	Open collector output (+) : Alarm 1 output
11	Open collector output (+) : Alarm 2 output
12	0V

• Auto setting (With gradient setter)

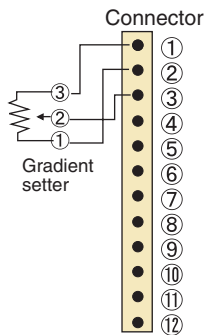

• Auto/Manual setting selection

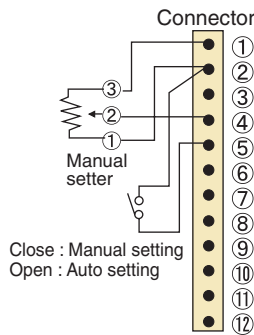

• Auto/Manual setting selection (With gradient setter)

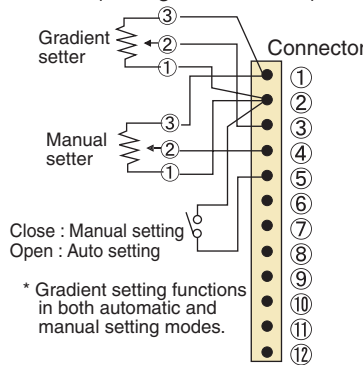

• Manual setting (With manual setter)

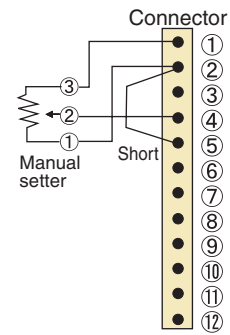

• External contact input

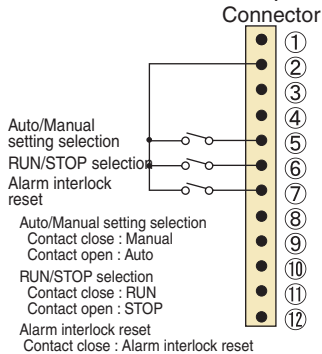

• ON/OFF control

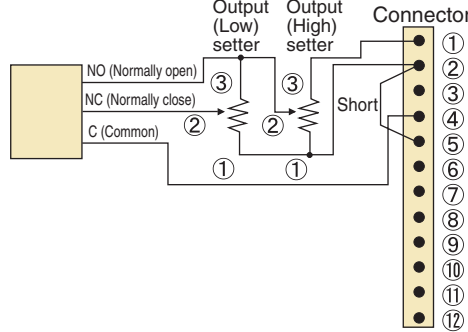

• Alarm output

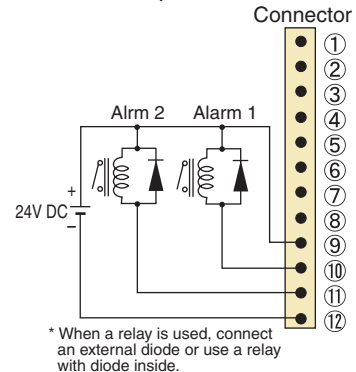

Accessories

- Gradient setter, Manual setter, High/Low setter : THVP-S01

Unit : mm

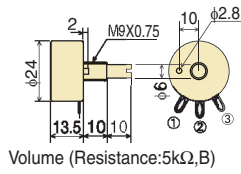

Volume (Resistance: 5kΩ, B)

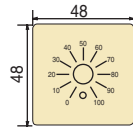

Scale plate

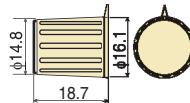

Knob

- Step-down transformer : THVP-T01

Unit : mm

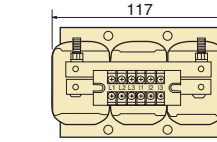

* When 400V to 440VAC is selected as power supply, step-down transformer (For instrument power supply) is supplied.

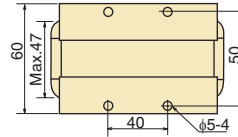
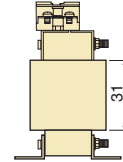
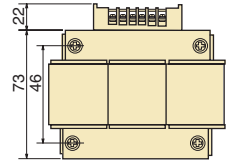

- Model code * Please refer to the following codes to order accessories.

Name	Model Code	Name	Model Code
Setter	THVP-S01	Terminal cover (For main circuit terminal)	200V : 20A, 30A, 45A, 60A THWP-A01
Connector (plug)	THWP-C01		400V : 20A, 30A, 45A, 60A THWP-A02
Voltage down transformer	THWP-T01		200V/400V : 80A, 100A THWP-A03

Name	Model Code
Fast-blow fuse (Unit : 1 piece)	20V 20A THWP-F20
	20V 30A THWP-F30
	20V 45A/60A THWP-F40
	20V 80A THWP-F80
	20V 100A THWP-FA0
	400V 20A THWP-F22
	400V 30A THWP-F32
	400V 45A/60A THWP-F42
	400V 80A THWP-F82
	400V 100A THWP-FA2

Name	Model Code
Fast-blow fuse with fuse break alarm (Unit : 1 piece)	20V 20A THWP-F21
	20V 30A THWP-F31
	20V 45A/60A THWP-F41
	20V 80A THWP-F81
	20V 100A THWP-FA1
	400V 20A THWP-F23
	400V 30A THWP-F33
	400V 45A/60A THWP-F43
	400V 80A THWP-F83
	400V 100A THWP-FA3

CAUTION

- Prevent metal fragments or load wire scraps from falling inside instrument to avoid electric shock, fire or malfunction.
- All wiring must be completed before power is turned on to prevent electric shock, fire or incorrect action.



Safety
Warning

• Before operating this product, read the instruction manual carefully to avoid incorrect operation.
 • This product is intended for use with industrial machines, test and measuring equipment. It is not designed for use with medical equipment.
 • If it is possible that an accident may occur as a result of the failure of the product or some other abnormality, an appropriate independent protection device must be installed.

• When installing this product, avoid the following:
 • Direct exposure to sunlight.
 • Direct contact with water.
 • Corrosive environments.
 • Hazardous areas containing explosive or flammable gases.
 • Vibration or shock.
 • Areas subject to electrical noise caused by inductive interference, static electricity or magnetic fields.

RKC® **RKC INSTRUMENT INC.**
 (RIKA KOGYO CO.,LTD)

HEAD OFFICE : 16-6, KUGAHARA 5 CHOME OHTA-KU TOKYO 146-8515 JAPAN
 PHONE : 03-3751-9799 (+81 3 3751 9799)
 Email : info@rkcinst.co.jp
 FAX : 03-3751-8585 (+81 3 3751 8585)
 http://www.rkcinst.com/