

**JUMO GmbH & Co. KG**  
 Delivery address: Mackenrodtstraße 14,  
 36039 Fulda, Germany  
 Postal address: 36035 Fulda, Germany  
 Phone: +49 661 6003-0  
 Fax: +49 661 6003-607  
 e-mail: mail@jumo.net  
 Internet: www.jumo.net

**JUMO Instrument Co. Ltd.**  
 JUMO House  
 Temple Bank, Riverway  
 Harlow, Essex CM 20 2TT, UK  
 Phone: +44 1279 635533  
 Fax: +44 1279 635262  
 e-mail: sales@jumo.co.uk  
 Internet: www.jumo.co.uk

**JUMO Process Control, Inc.**  
 8 Technology Boulevard  
 Canastota, NY 13031, USA  
 Phone: 315-697-JUMO  
 1-800-554-JUMO  
 Fax: 315-697-5867  
 e-mail: info@jumo.us  
 Internet: www.jumo.us



**JUMO** LOGOSCREEN 500 cf



# Entry-level Paperless Recorder with CompactFlash card and life-cycle data management

## Brief description

The appearance of the LOGOSCREEN 500 cf is dominated by a 5-inch color display, in which the measurement data can be displayed in a vertical direction, similar to ordinary chart recorders. But unlike ordinary recorders, the LOGOSCREEN 500 cf does not need any chart paper for recording. Measurement data are stored electronically, and are available for evaluation on the spot as well as in the PC.

The integrated life-cycle data management ensures fast traceability of process data referred to specific installations.

According to choice, the LOGOSCREEN 500 cf can be fitted with 3 or 6 electrically isolated measurement inputs. The recorder can be programmed from eight keys, or by using a PC via a CompactFlash card or a serial interface.

The bezel size is 144mm x 144mm, depth behind panel 214mm.



Type 706510/...

## Block structure

### 3/6 analog inputs

Thermocouples  
 Resistance thermometer  
 Voltage  
 Current

(the inputs are electrically isolated from one another)



**JUMO LOGOSCREEN 500 cf**

### Power supply

110 – 240 V AC or  
 20 – 53 V AC/DC

#### I/O card (extra code)

4 binary inputs  
 graphically displayed

3 relays  
 changeover (SPDT)  
 230 V, 3 A

RS232 and RS485  
 interface  
 for process and  
 configuration data



### Features

5" STN color screen  
 320 x 240 pixel, 27 colors

CompactFlash card  
 64/128/256 MB, for  
 transferring measurements  
 and configuring the  
 paperless recorder

CPU card  
 with main memory and  
 measurement data  
 memory  
 (FLASH memory)  
 for approx. 350,000  
 measurements



### Software (accessory)

Setup program  
 for configuration

Evaluation software  
 for representation and  
 evaluation of  
 measurement data

Communication software  
 for automatic data readout  
 (also via modem)



## Key features

- Measurement data presented numerically as vertical diagrams (with scaling, numerical display, or as a bar graph)
- Presentation of event traces such as "Binary inputs"
- On-site availability of measurements in the FLASH memory
- Measurement data are retained, even after a power interruption
- Saving of data sets on the CompactFlash card
- Instrument configuration through the keys or the setup program (CompactFlash card or serial interface)
- Evaluation of archived data with PC evaluation program
- Search function for history analysis
- Adaptation of the memory cycles to the specific process, using normal, event and time-of-day triggering
- Freely configurable inputs
- Internal sampling rate 250msec for 3 or 6 analog inputs, minimum storage cycle 1 sec
- Counters and integrators (6 channels)
- Math and logic module (6 channels)

## Technical data

### Analog inputs

#### Input for DC voltage, DC current

Basic range	Accuracy	Input resistance
-20 to +70mV	±80µV	$R_{IN} \geq 1 \text{ M}\Omega$
-3 to +105mV	±100µV	$R_{IN} \geq 1 \text{ M}\Omega$
-10 to +210mV	±240µV	$R_{IN} \geq 1 \text{ M}\Omega$
-0.5 to +12V	±6mV	$R_{IN} \geq 470 \text{ k}\Omega$
-0.05 to +1.2V	±1mV	$R_{IN} \geq 470 \text{ k}\Omega$
-1.2 to +1.2V	±2mV	$R_{IN} \geq 470 \text{ k}\Omega$
-10 to +12V	±12mV	$R_{IN} \geq 470 \text{ k}\Omega$
Shortest span	5mV	
Range start/end	freely programmable within the limits in 0.01 mV steps	
-2 to +22mA	±20µA	burden voltage ≤ 1V
-22 to +22mA	±44µA	burden voltage ≤ 1V
Shortest span	0.5mA	
Range start/end	freely programmable within the limits in 0.01 mA steps	
Overrange / underrange	according to NAMUR NE 43	
Sampling cycle	3 or 6 channels 250msec	
Input filter	2nd order digital filter; filter constant adjustable from 0 to 10.0sec	
Test voltage for electrical isolation	350V (via optocoupler)	
Resolution	> 14 bit	

### Thermocouple

Designation	Type	Standard	Meas. range	Accuracy <sup>1</sup>
Fe-Con	L	DIN 43 710	-200 to +900°C	±0.1 %
Fe-Con	J	EN 60 584	-210 to +1200°C	±0.1 % from -100°C
Cu-Con	U	DIN 43 710	-200 to +600°C	±0.1 % from -150°C
Cu-Con	T	EN 60 584	-270 to +400°C	±0.15 % from -150°C
NiCr-Ni	K	EN 60 584	-270 to +1372°C	±0.1 % from -80°C
NiCr-Con	E	EN 60 584	-270 to +1000°C	±0.1 % from -80°C
NiCrSi-NiSi	N	EN 60 584	-270 to +1300°C	±0.1 % from -80°C
Pt10Rh-Pt	S	EN 60 584	-50 to +1768°C	±0.15 % from 0°C
Pt13Rh-Pt	R	EN 60 584	-50 to +1768°C	±0.15 % from 0°C
Pt30Rh-Pt6Rh	B	EN 60 584	0 to 1820°C	±0.15 % from 400°C
W3Re/W25Re	D		0 to 2400°C	±0.15 % from 500°C
W5Re/W26Re	C		0 to 2320°C	±0.15 % from 500°C
Chromel-Copel		GOST R 8.585-2001	-200 to +800°C	±0.1 %
Shortest span	Type L, J, U, T, K, E, N, chromel-copel: Type S, R, B, D, C:			100°C 500°C
Range start/end	freely programmable within the limits, in 0.1°C steps			
Cold junction	Pt100 internal or thermostat external constant			
Cold junction accuracy (internal)	± 1°C			
Cold junction temperature (external)	-50 to +150°C, adjustable			
Sampling cycle	3 or 6 channels, 250msec			
Input filter	2nd order digital filter; filter constant adjustable from 0 to 10.0sec			
Test voltage for electrical isolation	350V (via optocoupler)			
Resolution	> 14 bit			
Special features	also programmable in °F			

1. The accuracy refers to the maximum measuring range. The accuracy is reduced with short spans.

## Resistance thermometers

Designation	Standard	Connection circuit	Meas. range	Accuracy	Measuring current
Pt100	EN 60 751 (TC = $3.85 \cdot 10^{-3} 1/^{\circ}\text{C}$ )	2/3-wire 2/3-wire 4-wire 4-wire	-200 to +100°C -200 to +850°C -200 to +100°C -200 to +850°C	$\pm 0.5^{\circ}\text{C}$ $\pm 0.8^{\circ}\text{C}$ $\pm 0.5^{\circ}\text{C}$ $\pm 0.5^{\circ}\text{C}$	500µA 250µA 500µA 250µA
Pt100	JIS 1604 (TC = $3.917 \cdot 10^{-3} 1/^{\circ}\text{C}$ )	2/3-wire 2/3-wire 4-wire 4-wire	-200 to +100°C -200 to +650°C -200 to +100°C -200 to +650°C	$\pm 0.5^{\circ}\text{C}$ $\pm 0.8^{\circ}\text{C}$ $\pm 0.5^{\circ}\text{C}$ $\pm 0.5^{\circ}\text{C}$	500µA 250µA 500µA 250µA
Pt100	GOST 6651-94 A.1 (TC = $3.391 \cdot 10^{-3} 1/^{\circ}\text{C}$ )	2/3-wire 2/3-wire 4-wire 4-wire	-200 to +100°C -200 to +850°C -200 to +100°C -200 to +850°C	$\pm 0.5^{\circ}\text{C}$ $\pm 0.8^{\circ}\text{C}$ $\pm 0.5^{\circ}\text{C}$ $\pm 0.5^{\circ}\text{C}$	500µA 250µA 500µA 250µA
Ni100	DIN 43 760 (TC = $6.18 \cdot 10^{-3} 1/^{\circ}\text{C}$ )	2/3-wire 4-wire	-60 to +180°C -60 to +180°C	$\pm 0.4^{\circ}\text{C}$ $\pm 0.4^{\circ}\text{C}$	500µA 500µA
Pt500	EN 60 751 (TC = $3.85 \cdot 10^{-3} 1/^{\circ}\text{C}$ )	2/3-wire 2/3-wire 4-wire 4-wire	-200 to +100°C -200 to +850°C -200 to +100°C -200 to +850°C	$\pm 0.5^{\circ}\text{C}$ $\pm 0.8^{\circ}\text{C}$ $\pm 0.5^{\circ}\text{C}$ $\pm 0.5^{\circ}\text{C}$	250µA 250µA 250µA 250µA
Pt1000	EN 60 751 (TC = $3.85 \cdot 10^{-3} 1/^{\circ}\text{C}$ )	2/3-wire 2/3-wire 4-wire 4-wire	-200 to +100°C -200 to +850°C -200 to +100°C -200 to +850°C	$\pm 0.5^{\circ}\text{C}$ $\pm 0.8^{\circ}\text{C}$ $\pm 0.5^{\circ}\text{C}$ $\pm 0.5^{\circ}\text{C}$	500µA 250µA 500µA 250µA
Pt50		2/3-wire 2/3-wire 4-wire 4-wire	-200 to +100°C -200 to +1100°C -200 to +100°C -200 to +1100°C	$\pm 0.5^{\circ}\text{C}$ $\pm 0.9^{\circ}\text{C}$ $\pm 0.5^{\circ}\text{C}$ $\pm 0.6^{\circ}\text{C}$	500µA 250µA 500µA 250µA
Cu 50	(TC = $4.26 \cdot 10^{-3} 1/^{\circ}\text{C}$ )	2/3-wire 2/3-wire 4-wire 4-wire	-50 to +100°C -50 to +200°C -50 to +100°C -50 to +200°C	$\pm 0.5^{\circ}\text{C}$ $\pm 0.9^{\circ}\text{C}$ $\pm 0.5^{\circ}\text{C}$ $\pm 0.6^{\circ}\text{C}$	500µA 250µA 500µA 250µA
Cu100	GOST 6651-94 A.4 (TC = $4.26 \cdot 10^{-3} 1/^{\circ}\text{C}$ )	2/3-wire 4-wire	-50 to +200°C -50 to +200°C	$\pm 0.5^{\circ}\text{C}$ $\pm 0.5^{\circ}\text{C}$	500µA 500µA
Connection circuit	2-, 3-, or 4-wire circuit				
Shortest span	15°C				
Sensor lead resistance	max. 30 Ω per conductor for 3-wire/4-wire circuit max. 10 Ω per conductor for 2-wire circuit				
Range start/end	freely programmable within the limits in 0.1°C steps				
Sampling cycle	3 or 6 channels, 250msec				
Input filter	2nd order digital filter; filter constant adjustable from 0 to 10sec				
Test voltage for electrical isolation	350V (via optocoupler)				
Resolution	> 14 bit				

## Transducer short circuit/break

	Short circuit <sup>1</sup>	Break <sup>1</sup>
Thermocouple	not detected	detected
Resistance thermometers	detected	detected
Voltage ≤ 210mV	not detected	detected
Voltage > 210mV	not detected	not detected
Current	not detected	not detected

1. Programmable reaction of device, e.g. trigger an alarm

## Binary inputs (extra code)

Quantity	4, to DIN 19 240; 1Hz max., 32V max.
Level	logic "0": -3 to +5V, logic "1": 12 – 30V
Sampling cycle (binary inputs, without counter function)	1 sec
Count frequency (binary inputs, with counter function)	30Hz max.
Auxiliary voltage (output)	24V ±10%, 50mA (short-circuit proof)

**Outputs (extra code)**

3 relays	changeover (SPDT) (3A, 230V)
----------	------------------------------

**Serial interface**

Setup interface (standard)	to read and write measurement, instrument, and configuration data (Modbus protocol)
RS232 / RS485 (extra code)	to read and write measurement, instrument, and configuration data (Modbus protocol)

**Screen**

Resolution	320 x 240 pixels
Size	5"
Number of colors	27 colors
Screen refresh rate	≥150Hz
Contrast setting	adjustable on instrument
Screen saver (switch-off)	through waiting time or control signal

**Electrical data**

Supply (switch-mode PSU)	110 – 240 V AC +10/-15%, 48 – 63Hz or 20 – 53V AC/DC, 48 – 63Hz
Test voltages (type test)	to EN 61 010, Part 1, March 1994 overvoltage category II, pollution degree 2 for supply voltage: AC 2.3kV/50Hz, 1 min, for supply voltage: AC/DC 510V/50Hz, 1 min for supply voltage: AC 2.3kV/50Hz, 1 min, for supply voltage: AC/DC 510V/50Hz, 1 min
- electrical supply to measuring circuit	350V/50Hz, 1 min
- electrical supply to housing (protective earth)	up to 30V AC and 50V DC
- measuring circuits to other measuring circuits and housing	
- electrical isolation between the analog inputs	
Supply voltage error	< 0.1 % of range span
Power consumption	approx. 25VA
Data backup	see page 6
Electrical connection	At the back, via pluggable screw terminals, conductor cross-section ≤ 2.5mm <sup>2</sup> or 2 x 1.5mm <sup>2</sup> with core end ferrules.
EMC	EN 61 326 Class A to industrial requirements
- interference emission	
- interference immunity	
Safety regulations	to EN 61 010
Enclosure protection	to EN 60 529 category 2, front IP54, back IP20
Ambient temperature range	0 to +50°C
Ambient temperature error	0.03 %/°C
Storage temperature range	-20 to +60°C

**Housing**

Housing type - housing door	housing for flush panel mounting to DIN 43 700, galvanized steel sheet zinc die-casting
Bezel size	144 mm x 144 mm
Depth behind panel	214 mm, including connectors
Panel cut-out	138 <sup>+1.0</sup> mm x 138 <sup>+1.0</sup> mm
Panel thickness	2 – 40 mm
Housing mounting	in panel to DIN 43 834
Climatic conditions	≤ 75% relative humidity, no condensation
Operating position	unrestricted, but taking into account the viewing angle of the screen, horizontally ±50°, vertically ±30°
Enclosure protection	to EN 60 529 Category 2, at front, IP54 (IP65 with extra code 266), at back, IP20
Weight	approx. 3.5kg

## Operation and configuration

### On the recorder

Configuration is menu-led, using 8 keys. Three of these have fixed functions assigned (Enter, Menu, Exit), and five alter their function and visual representation according to the menu. The currently active functions are shown on the bottom edge of the screen, so that key functions are always unambiguous during use.



The configuration on the recorder is protected from unauthorized access by a code number.

### Via setup program for PC (accessory)

Instrument configuration via the setup program for the PC is more convenient than using the keys on the instrument itself.

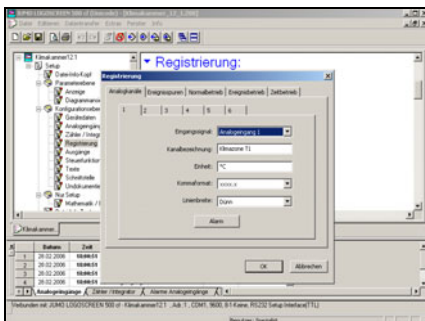

The configuration data can be created on a data medium (CompactFlash card) and read into the recorder, or transferred to the instrument via a serial interface. The PC can be used to output the settings to a printer.

## Operating language

The operating language for the instrument can be configured in various languages. English, German, French, Dutch, Spanish, Italian, Hungarian, Czech, Swedish, Polish, Danish, Finnish, Portuguese and Russian have been implemented.

Others on request.

## Evaluation program

The PC evaluation program (PCA3000) is a program that runs under Windows NT/2000/XP, and is used to manage, archive, visualize and evaluate the recorder data that have been stored on a CompactFlash card.

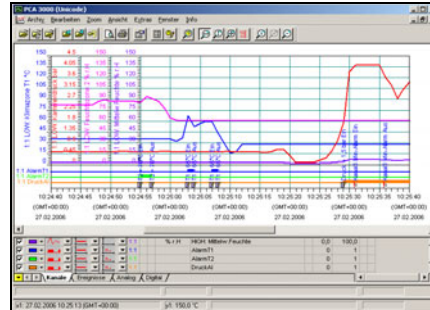

- The data from the LOGOSCREEN 500 cf are read in by the evaluation program and saved in an archive file. The lifecycle data management ensures that, if needed, all the data throughout the lifetime of a system can be saved in an archive file. Changes to the configuration are shown separately, together with the corresponding measurement data.
- The user can gain access at any time to certain data sets (configuration), which can be distinguished by supplementary information. In addition, it is possible to restrict the time periods to be evaluated.
- Any analog channels or event traces of a paperless recorder can subsequently be combined into PCA groups in PCA3000.
- Since each group is displayed in a separate window, several groups can be shown simultaneously on the screen and compared.
- Operation by mouse or keys.
- The export filter makes it possible to export the stored data for processing in another program (e.g. Excel).
- The PCA3000 evaluation program supports network capability, i. e. several users can obtain data from the same database in the network, independently of one another.

### PCA communications software (PCC)

- The data can be read out from the paperless recorder via the serial interface (RS232/RS485) on the back, or via the setup interface on the front. The data can be read out manually or automatically (e.g. daily at 23.00 hrs).
- Data can also be retrieved via remote control, through a modem.

## Interface

- The current process data, configuration data and special instrument data can be read out via the RS232 and RS485 interface (available with extra code) or through the setup interface that is fitted as standard. The archive data (FLASH memory) can also be read out, in conjunction with the PCC software. A maximum cable length of 15m is permitted when using the RS232 interface. For the RS485 interface, a maximum cable length of 1.2km is permitted. Connection is by a 9-pin SUB-D connector at the back of the instrument (for the RS232/RS485) or at the front (for the setup interface). Modbus and Jbus protocols are available, and the transmission mode used is RTU (Remote Terminal Unit).
- The changeover between the RS232 and the RS485 interface is made through the programming (configuration).

## Extra codes

### Counters/integrators/operating time counters

6 additional internal channels are available for use as counters, integrators or operating time counters. These counters are controlled through the binary inputs, the alarms, or via the logic channels. The numerical indication is shown in a separate window, with a maximum of 9 figures. The acquisition period can be selected as: periodic, daily, weekly, monthly, yearly as well as externally, total (overall count) or daily from ... to.

06:57:03	Klinikammer 12.1	1 s	99%
01.03.06	T1 > 65°C	AUS	
AnzahlAlarm Temperatur1 +3 mal			
AnzahlAlarm Temperatur2 +7 mal			
Alarmdauer pro Tag +16 min.			
Alarmdauer pro Woche +0.7 h			
Kühlw.Verbr. pro Tag +377.2 l			
Kühlw.Verbr. pro Woche +3465.5 l			

### Math/logic module

The module for math and logic (only configurable via the setup software) enables, for instance, the combination of analog channels with one another, with counters and/or with the binary inputs. The operators available for formulae are: +, -, \*, /, (, ), SQRT(), MIN(), MAX(), SIN(), COS(), TAN(), \*\*, EXP(), ABS(), INT(), FRC(), LOG(), LN(), humidity, moving average or !, &, |, ^, as well as ( and ).

## Operating principle

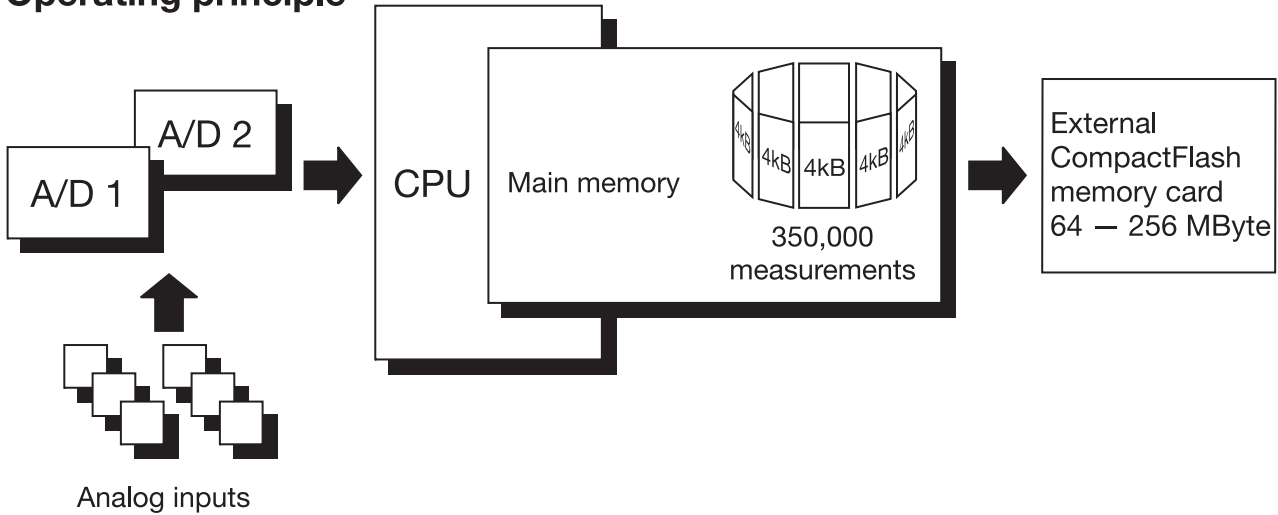

## Data processing

The measurements from the analog inputs are acquired continuously in a 250msec sampling cycle. These measurements also serve as the basis for limit monitoring. The measurements are transferred to the main memory of the instrument, according to the configurable storage cycle and stored value (average, momentary value, maximum, minimum, or peak value).

### Main memory (FLASH memory)

The data stored in the main memory are regularly copied to the Compact Flash card in 4 kbyte blocks. The main memory is written to as a ring memory, i.e. when it is full, the oldest data will automatically be overwritten by new data. The memory capacity is sufficient for approx. 350,000 measurements.

The instrument monitors the capacity of the main memory and activates the “Memory alarm (internal)” signal if the level falls below a configurable residual capacity.

### CompactFlash card

For saving the data, CompactFlash cards (industrial grade) can be used with the following storage capacities: 64/128/256MB. The instrument monitors the capacity of the CompactFlash card, and activates the “Memory alarm (CF card)” signal if the level falls below a configurable residual capacity. This signals can be used, for instance, to operate a relay (warning signal “Swap CF card”).

### Data security

The data are stored in coded form in a proprietary format. If the CompactFlash card is removed from the instrument, no data will be lost immediately, as these data are still stored in the FLASH memory. A loss of data will only occur if, after the CompactFlash card has been removed, the FLASH memory is completely rewritten as well.

### Response to disconnection of the instrument from the electrical supply

- Configuration and measurement data will be retained, even after the paperless recorder has been disconnected from the electrical supply.
- When the lithium battery, supplied ex-factory, is exhausted ( $\geq 10$  years) or the storage capacitor (available on request) is discharged (typically 2 weeks), all measurements that have not yet been saved on a CompactFlash card, as well as the time, will be lost.

### Recording duration

Depending on the configuration of the instrument, the duration of the recording can vary over a considerable range (from a few days up to several months).

### Limit monitoring/ operating mode changeover

An over/underlimit condition will trigger an alarm. The alarm can be output through a relay or used as a control signal for changing over the operating mode from normal/timed operation to event operation. The storage cycle and stored value can be configured separately for all three operating modes. With the help of the alarm delay function, brief occurrences of over/underlimit conditions can be filtered out, with the result that no alarm is generated.

### Normal operation

If the instrument is **not** in event operation and **not** in timed operation, then normal operation is active by default.

### Event operation

Event operation is activated/terminated by a control signal (binary input, combination alarm). As long as this control signal is active, the instrument is in event operation.

### Timed operation

Timed operation is active on a daily basis within a programmable time period. The operating modes have different priorities.

Operating mode	Priority
Event operation	1 (higher)
Timed operation	2
Normal operation	3 (lower)

# Presentation modes on the instrument

## Main menu



- Branching into the menus (levels)
  - visualization
  - parameterization
  - configuration
  - event list
  - CF card manager
  - device info

## Visualization

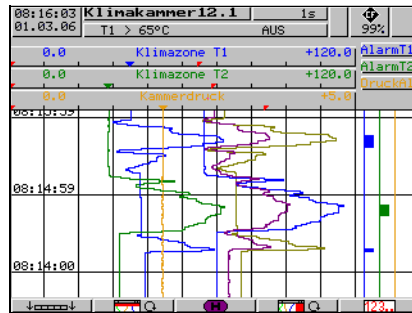

- Analog channels and event traces
- In addition to the curves, measurements can be made visible in numerical form, with scaling or as a bar graphs.
- Softkeys can be made visible or hidden.

## Visualization

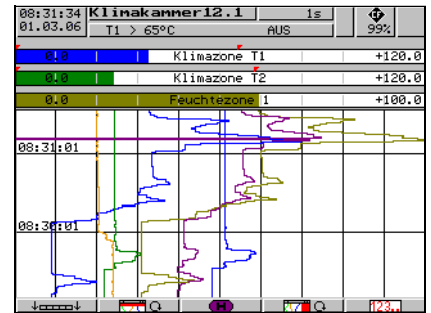

- Graphical presentation of the analog channels (without event traces)
- Display of scaling and limit markers for the channels

## Visualization



- Display mode "Measurements" (numerical display)



- Display mode "Scaling" including limit markers



- Display mode "Bar graph" including limit markers

## Visualization

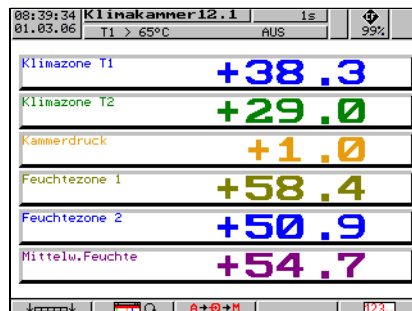

- The graphical presentation can be switched off in favor of a larger numerical display.

## History presentation

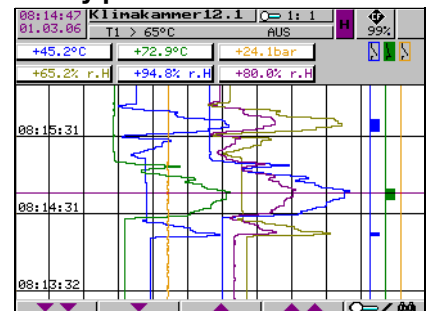

- All stored measurement data are shown as curves at different zoom levels.
- Numerical display of the measurements for the analog channels at the cursor position.
- Shifting of the visible section within the stored measurement data.
- When recorded as an envelope: the maximum or minimum value display can be changed within the channel line.

## Configuration

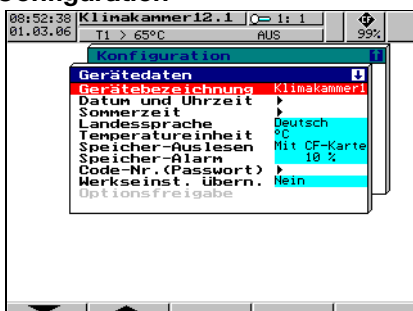

- Configuration from instrument keys
- Password-protected
- Configuration can be transferred to CF card
- Configuration data can be read/alterted through the setup program

## Parameterization

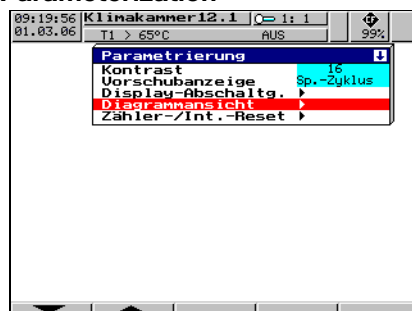

- General settings without password
- Selection of the presentation mode, such as: analog data and/or event traces with/without channel line

## Event list

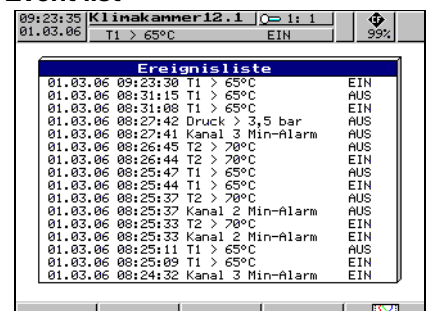

- Important events in plain text (alarm messages, external texts or system messages)

### Connection diagram

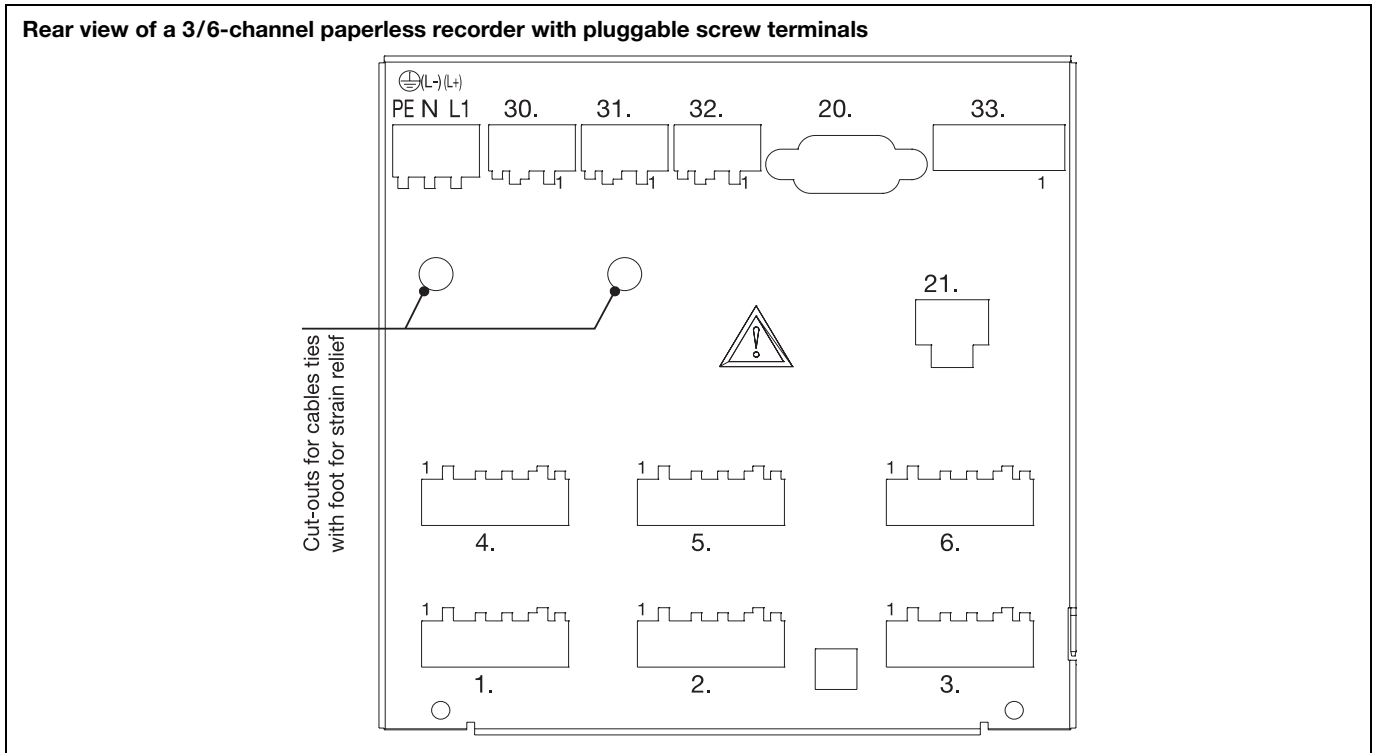

Terminal assignments for 3/6-channel paperless recorder		Diagram
Analog inputs	Connector	
Thermocouple	1 to 6	
Resistance thermometer in 2-wire circuit	1 to 6	
Resistance thermometer in 3-wire circuit	1 to 6	
Resistance thermometer in 4-wire circuit	1 to 6	
Voltage input ≤ 210mV	1 to 6	
Voltage input > 210mV	1 to 6	
Current input	1 to 6	

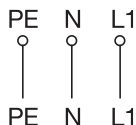
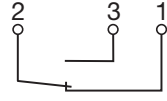
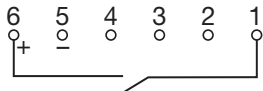
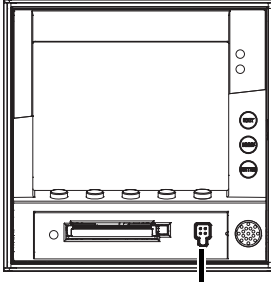
<b>Supply</b>			
Supply	PE  N (L-) L1 (L+)		
<b>Relay outputs (extra code)</b>			
Relays K1, K2, K3 changeover (SPDT)	30, 31, 32		
<b>Interfaces (extra code)</b>			
RS232C 9-pole SUB-D socket (switchable to RS485)	20	2 RxD 3 TxD 5 GND	Received Data Transmitted Data Ground
RS485 9-pole SUB-D socket (switchable to RS232)	20	3 TxD+/RxD+ 5 GND 8 TxD-/RxD-	Transmitted/Received Data + Ground Transmitted/Received Data -
Ethernet (under development) RJ45 socket (extra code)	21	1 TX+ 2 TX- 3 RX+ 6 RX-	Transmitted Data + Transmitted Data - Received Data + Received Data -
<b>Binary inputs (extra code)</b>			
Supply voltage 24V/50mA Binary inputs voltage-controlled LOW = -3 to +5V DC HIGH = 12 to 30V DC	33 6 +24V auxiliary supply 5 GND 4 binary input 1 3 binary input 2 2 binary input 3 1 binary input 4	 Example: binary input 4, operated from the internal supply voltage	
<b>Setup interface (included in delivery)</b>			
The setup interface can be found behind a protective flap on the front of the instrument.		 Setup interface	

**Dimensions**

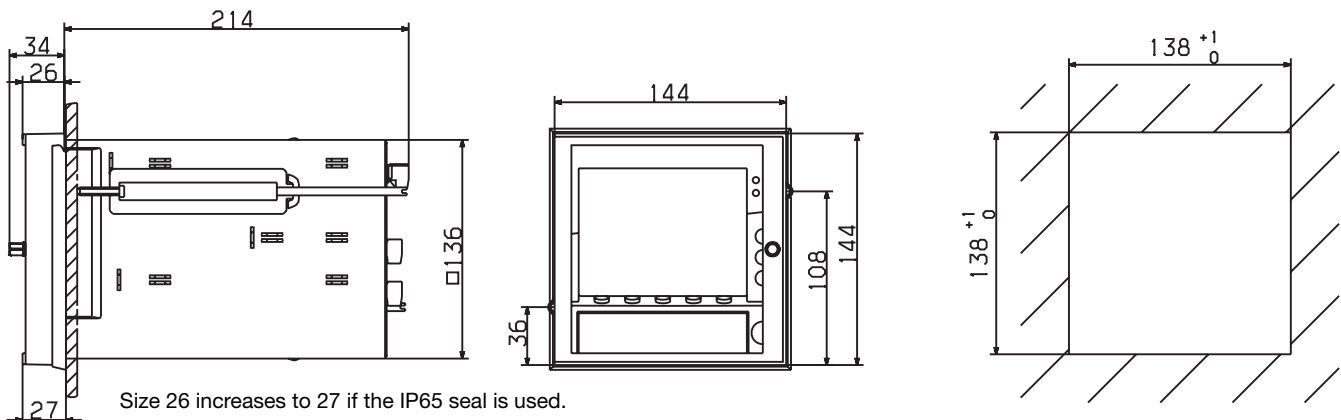

## Order details

Entry-level Paperless Recorder with CompactFlash card as storage medium and life-cycle data management

(1) Basic version	
706510/14	Paperless recorder with 3 analog inputs
706510/24	Paperless recorder with 3 analog inputs incl. setup and PC evaluation program (PCA3000)
706510/15	Paperless recorder with 6 analog inputs
706510/25	Paperless recorder with 6 analog inputs incl. setup and PC evaluation program (PCA3000)
(2) External memory	
x x x x 0000	no external memory
x x x x 0064	64MB CompactFlash memory card
x x x x 0128	128MB CompactFlash memory card
x x x x 0256	256MB CompactFlash memory card
(3) Supply voltage	
x x x x 22	20 – 53V AC/DC, 48 – 63Hz
x x x x 23	110 – 240V AC +10/-15%, 48 – 63Hz
(4) Extra codes	
x x x x 008	Ethernet interface (under development)
x x x x 020	Lithium battery for memory buffering (ex-factory)
x x x x 021	Storage capacitor (instead of extra code 020)
x x x x 260	Integrators and counters, as well as math and logic module (the math and logic module can only be configured through the setup program).
x x x x 261	4 binary inputs, 3 relay outputs, serial interface RS232/RS485 (Modbus, Jbus)
x x x x 265	Door with lock (IP54)
x x x x 266	IP65 seal, wide mounting brackets
x x x x 350	Universal carrying case TG-35

Order code  -  -  /  , ...<sup>1</sup>  
 Order example 706510/14 - 0064 - 23 / 020

<sup>1</sup> List extra codes in sequence, separated by commas.

### Standard accessories

- 1 Operating Manual B 70.6510.0
- 2 mounting brackets
- Cable tie with foot (can be released), for strain relief of the connecting cables to the sensors

### Accessories

	Sales No.
- Setup program, multilingual	70/00467262
- PC evaluation software (PCA3000), multilingual	70/00431882
- PCA communications software (PCC), multilingual	70/00431879
- PC interface with TTL/RS232 converter and adapter (socket)	70/00350260
- PC interface with USB/TTL converter, adapter (socket) and adapter (plug)	70/00456352
- Converter cable, USB serial (RS232)	70/00408077
- It is only possible to enable extra code 260 (configuration of the math and logic module) by using the setup program	70/00393217

## Universal carrying case TG-35

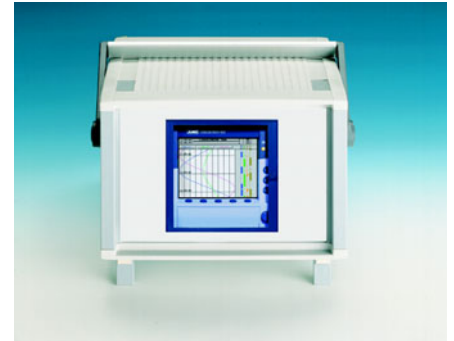

- for the installation of a paperless recorder with bezel size 144mm x 144mm
- 326mm x 227mm x 366mm (W x H x D)  
Cut-out: 138mm x 138mm
- The paperless recorder is accessible from the back