

# POWER CONTROLLER

## THV SERIES Power Controller Single Phase Thyristor Unit



UL/CSA  
(20,30A Type)



UL/cUL  
(Above 45A Type)

**RKC**® RKC INSTRUMENT INC.

# Compact and space-saving size

## ● Easy and accurate setting

Single phase power controller has an LED display to show set values and input signals and front keys for easy setting and monitoring. Setting can also be made with an external setting unit (variable resistor). Gradient setting, ramp-up (soft-start), ramp-down (soft-down) and high/low output limiters are supplied as standard.

## ● Works against a rapid response

With either the ramp-up (soft-start) or ramp-down (soft-down) set to zero, the THV quickly responds to setting input changes, and can be used in applications like RTP (Rapid Thermal Process).

## ● Wide supply voltage and auto-detecting power frequency

The THV operates at 100 up to 240V AC and automatically selects power supply frequency 50 or 60Hz.



## Three types of control modes are selectable

### ● Phase control

The waveform of the load power is switched at a desired phase angle  $\theta$  to provide smooth control.



### ● Zero-cross control (Continuous proportion)

Power is switched on and off when the supply voltage is at 0V. This system suppresses high frequency noise inherent to phase control.



### ● Zero-cross control (Input synchronization system)

Supply voltage is switched on and off according to the voltage pulse and contact signals from a controller.

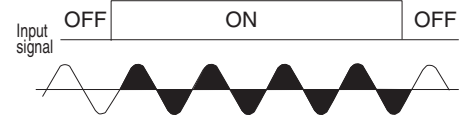

## Standard Functions

### Gradient setting

The relation between the setting input and the output voltage can be set. Gradient setting is possible via front keys or an external setter. Control characteristics may vary with the setting as follows.

1. Auto setting input X Internal gradient setting X External gradient setting
2. Auto setting input X Internal gradient setting
3. Manual setting X Internal gradient setting X External gradient setting

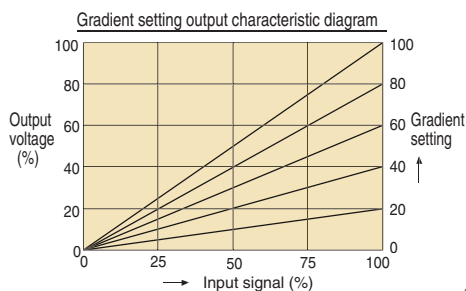

### Ramp function (Soft-start & Soft-down)

Even if setting input changes abruptly, output changes slowly to suppress inrush current. Ramp-up (Start-up) and ramp down (Start-Down) time can be set in the range of 0.1 to 99.9 sec via front keys.

Soft-start & Soft-down action diagram

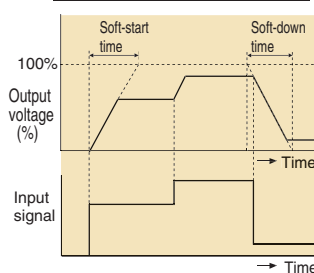

### Output limiter (High & Low)

Output highest and lowest values can be set via front keys.

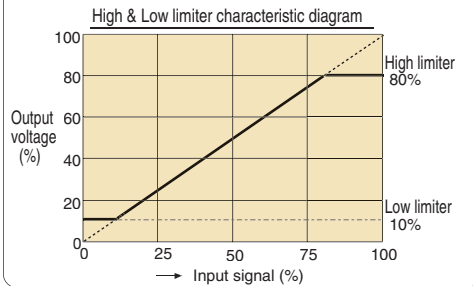

### Base-up setting (Output bias)

Output when the setting input is zero can be set via front keys. (Base-up setting is valid when output limiter low is set to 0.0)

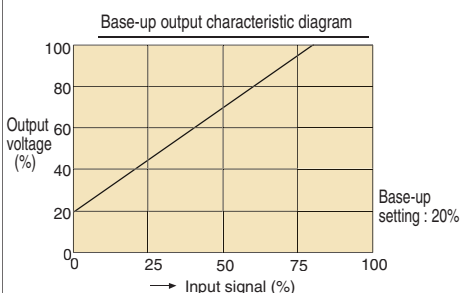

### 3 type of output modes

When phase control is selected for linear load (R: resistor), output mode can be selected from Proportional phase angle to input, proportional voltage to input, and proportional square voltage (electric power) to input.

\* Default setting is proportional square voltage to input.

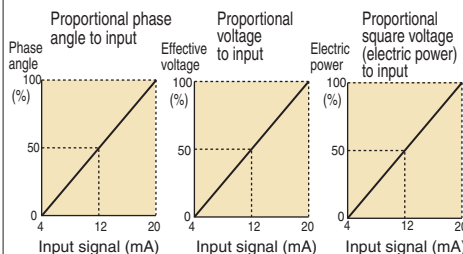

### Heater break alarm (Option)

This functions measures load current and compares it with a heater break alarm set value. Alarm will be activated if the load current varies outside of user defined levels, high or low.

(Note) Alarm does not work when loads are less than 15% of maximum load current.

### Load current limiter (Option, Only phase control)

This function limits the load current value to the heater.

\* If the load has a large inrush current, please use this function in combination with a soft-start function, as the load current limiter cannot suppress the inrush current when it is used alone for such an application.

### Constant current control (Option, Only phase control)

This function maintains the output current constant when a load or a power supply fluctuates. It makes the THV Series suitable for heaters of which resistance greatly changes by temperature change, such as Platinum, Molybdenum, Tungsten, and Tantalum heaters.

## Specifications

Rated current	20A, 30A, 45A, 60A, 80A, 100A AC	Allowable ambient temperature	Performance guarantee range: 0 to +40°C Operating guarantee range: -15 to +55°C
Control method	Phase control/ Zero-cross control (Selectable)	Allowable ambient humidity	5 to 95%RH (Non-condensing)
Applicable load	Phase control : Linearity (R:Resistor) load, Control of primary side of a transformer (magnetic field density 0.8T or less) Zero-cross control : Linearity (R:Resistor) load	Dielectric voltage	Between main circuit, power terminals and radiation fins : 2000V AC for one minute.
Input signal	Current input 4 to 20mA DC (Input impedance : 100 Ω) Voltage input 1 to 5V DC (Input impedance : 30kΩ) Voltage input 0 to 10V DC (Input impedance : 68kΩ) Voltage pulse input 0/12V DC (Input impedance : 30kΩ) Non-voltage contact input (Input impedance : 47kΩ)	Insulation resistance	Between main circuit, power terminals and radiation fins : 20M Ω or more (500V DC)
Min. load current	0.6A (20A type), 1A (30A, 45A, 60A, 80A, 100A type)	Mounting method	Vertical mounting
Power off leakage current	27 mA AC rms or less (Load voltage 200 V rms, 60 Hz, Ta=25°C)	Weight	Approx. 0.9kg (20A, 30A), Approx. 1.4kg (45A, 60A), Approx. 1.9kg (80A, 100A)
Output voltage range	0 to 98% of rated voltage	Standard functions	<ul style="list-style-type: none"> <li>Auto/Manual setting selection (External manual setting is option)</li> <li>Gradient setting (External setting is option)</li> <li>Soft-up/Soft-down : 0.0 to 99.9sec</li> <li>ON/OFF control (External high/low setting is option)</li> </ul>
Power supply voltage	90 to 264V AC (Including power supply voltage variation) [Rating : 100 to 240V DC]	Option function	<ul style="list-style-type: none"> <li>Heater break alarm</li> <li>Current measuring accuracy : ±2A (20A, 30A type) ±10% of Max. load current (45A, 60A, 80A, 100A type)</li> <li>Number of alarm delay times : 0 to 99 times</li> <li>Output : Open collector output, 24V DC, Max. 100mA</li> <li>Load current limiter (Only phase control)</li> <li>Constant current control (Only phase control)</li> <li>Stability : Within ±2% of full scale (Power supply variation : Within ±10%, Load variation : 2 times)</li> </ul>
Power frequency	50/60Hz (Automatic discriminating)	Standard	Safety standards: UL: UL508 (file No. E177758) cUL: C22.2 No.14 (file No. E177758) CSA: C22.2 No.14 (20A, 30A types) CE marking (20 A and 30 A types): LVD: EN60947-4-3 OVERVOLTAGE CATEGORYII, POLLUTION DEGREE 2, Class II (Reinforced insulation) EMC: EN60947-4-3 THV-1 conforms to CE marking by using the noise filter.
Allowable power frequency variation	±1Hz (Performance guarantee range) ±2Hz (Operating guarantee range)		
Output setting range	Gradient setting : 0.0 to 100% [Front key or external setting unit] Output limiter (High) : 0.0 to 99.9% [Front key or external setting unit] Output limiter (Low) : 0.0 to 99.9% [Front key or external setting unit] Base-up setting (Output bias) : 0.0 to 99.9% [Front key] Manual setting : 0.0 to 99.9% [Front key] 0.0 to 100% [External setting unit]		
Output mode	When phase control is selected for linearity load (R: resistor), output mode can be selected from Proportional phase angle to input, proportional voltage to input, and proportional square voltage (electric power) to input.		
Cooling method	Natural convection		

### • Temperature characteristics of load current

The rated current drops when the ambient temperature exceeds 40°C. The temperature inside the control panel increases due to heat generation of this instrument itself. Therefore, take into account full ventilation by mounting forced ventilation fans on the panel.

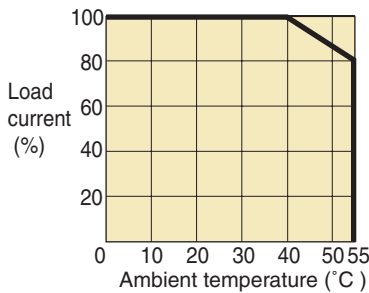

• Install the instrument as illustrated in the drawing to increase the cooling effect.

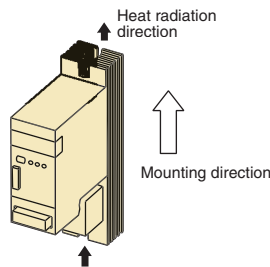

### • Table of internal calorific value

Rated current (A)	20	30	45	60	80	100
Internal calorific value (W)	30	43	63	84	112	140

### • CE Marking

THV-1 conforms to CE marking by using the noise filter.  
(Only for 20 A and 30 A type)  
The noise filter specified : SOSHIN ELECTRIC CO., LTD.  
LF2030A-NH

## Model and Suffix Code

Specifications	Model and Suffix Code						
Type	THV						
Power supply	Single-phase 100 to 240V AC						
Control method	Phase control/Zero-cross control (Default : Phase control)						
Rated current	20A AC	.....	.....	.....	.....	.....	.....
	30A AC	.....	.....	.....	.....	.....	.....
	45A AC	.....	.....	.....	.....	.....	.....
	60A AC	.....	.....	.....	.....	.....	.....
	80A AC	.....	.....	.....	.....	.....	.....
	100A AC	.....	.....	.....	.....	.....	.....
Input signal	0 to 10V DC	.....	.....	.....	.....	.....	.....
	1 to 5V DC	.....	.....	.....	.....	.....	.....
	4 to 20mA DC	.....	.....	.....	.....	.....	.....
Option function 1	No heater break alarm, constant current control and load current limiter					.....	
	With heater break alarm, constant current control and load current limiter *2					.....	
Option function 2	No option function 2					.....	
Accessories	Setter (Volume, Knob, Scale plate) 1 unit + Connector (Plug)	.....	.....	.....	.....	.....	- 1
	Setter (Volume, Knob, Scale plate) 2 units + Connector (Plug)	.....	.....	.....	.....	.....	- 2
	Fuse unit (Fast-blow fuse [1 piece]+ Holder [3 circuit type])	.....	.....	.....	.....	.....	- 3
	Output voltmeter : 150V span (For phase control)	.....	.....	.....	.....	.....	- 4
	Output voltmeter : 300V span (For phase control)	.....	.....	.....	.....	.....	- 5
	Fuse unit (Fast-blow fuse [1 piece] + Holder [1 circuit type])	.....	.....	.....	.....	.....	- 6
Connector (Plug)	.....	.....	.....	.....	.....	- 9	

\*1: Input signals 1 to 5V DC, 4 to 20mA DC and voltage pulse input are switchable with short bars (0 to 10V DC input is not switchable).

For a contact input, specify the connector as an accessory as input comes via a connector.

\*2: Constant current control and current limiter are not available to zero-cross control.

\*3: Setters are for external gradient setter, external manual setter, high/low external setter for ON/OFF control.

(Use two pieces of setter if gradient setting and manual setting are performed externally, or high/low setting for on/off control is performed, two setters are required.)

\*4: Specify two or more types simultaneously with the exception of the following combinations : -1-3 : Setter, with fuse unit and connector, -1-2-9 and -4-5 cannot be specified simultaneously.

\*5: Accessories are not in compliance with UL/CSA.

External Dimensions Unit: mm

○ 20A, 30A type

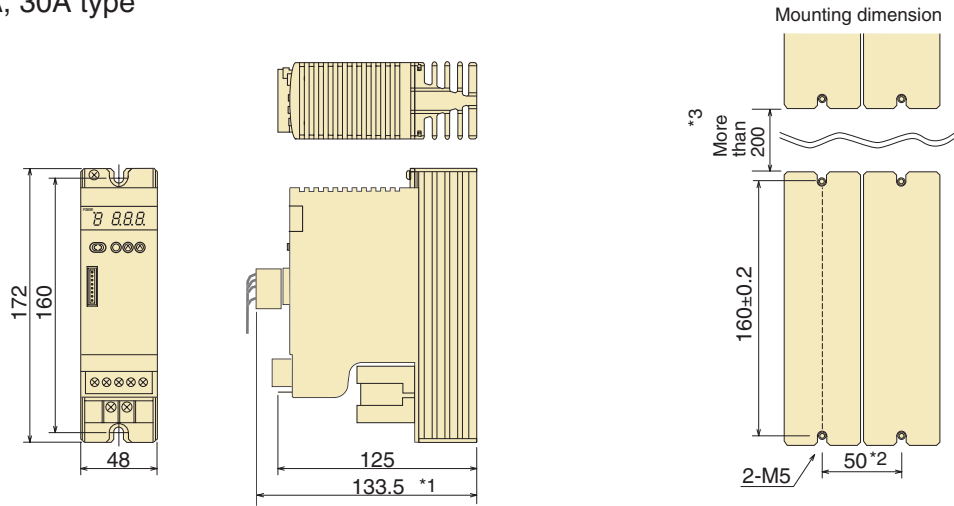

○ 45A, 60A type

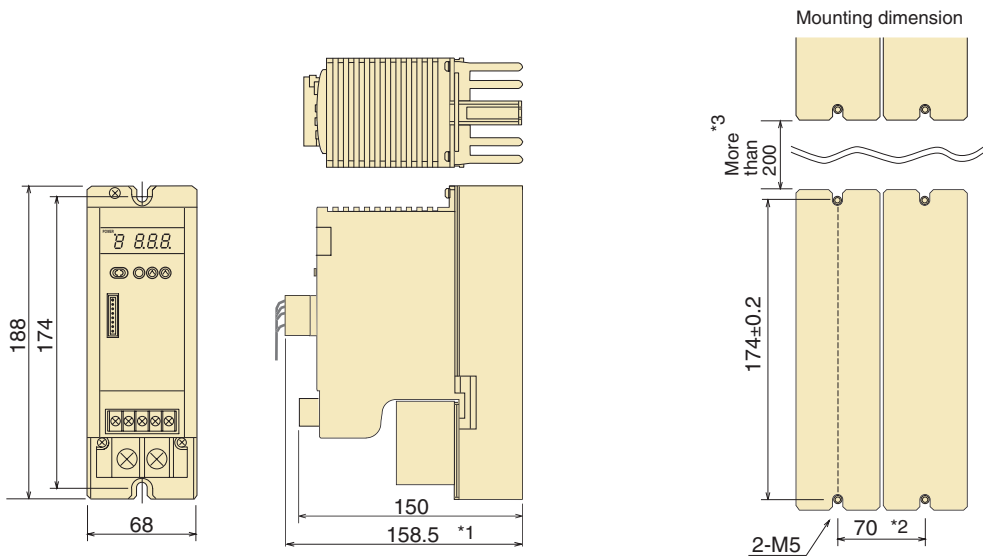

○ 80A, 100A type

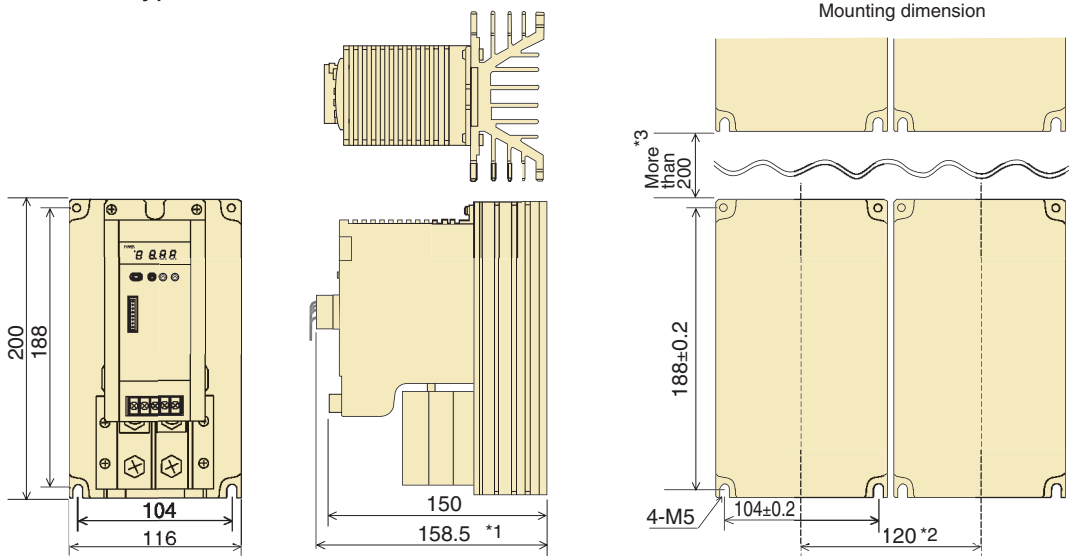

\*1 : Dimensions when the connector plug (optional) is connected.  
 When connecting the connector plug, install the power controller by taking enough space for its wiring into account.  
 \*2 : Minimum space when mounted closely side by side.  
 \*3 : Some space for heat radiation is required in the vertical direction between the lower and upper ends of the instruments. Therefore, make a space of at least 200 mm between them.

# External Wiring

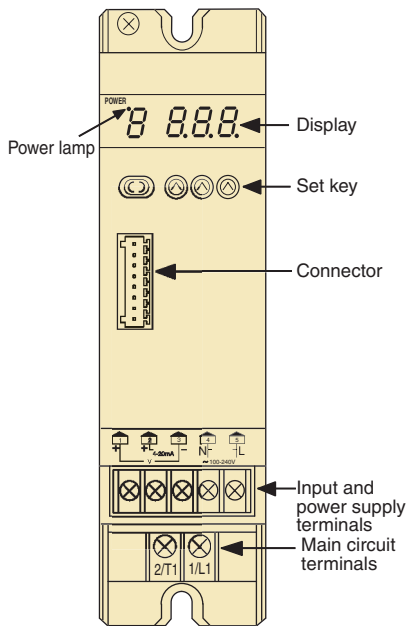

## Main circuit

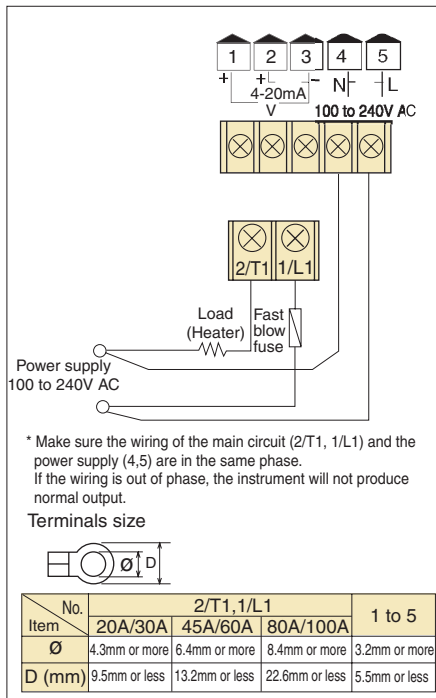

## Input signal



## Contact input

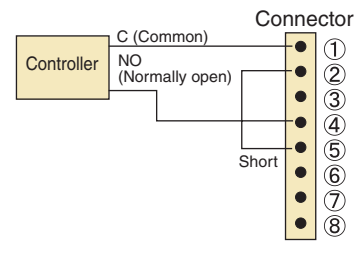

Pin No.	Contents
1	+5V output
2	0V (GND)
3	Gradient setting input (0 to 5V input by gradient setter)
4	Manual setting input (0 to 5V input by manual setter)
5	Auto/manual setting selection (Open:Auto setting) • External contact input Shorting pins No.2 (GND) with No.5 pin results in the manual setting mode.
6	Open collector output (+) : Heater break alarm output
7	Open collector output (-) : Heater break alarm output
8	Unused

### • Auto setting (With gradient setter)

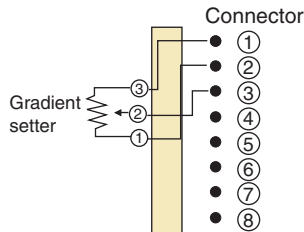

### • Auto/Manual setting selection

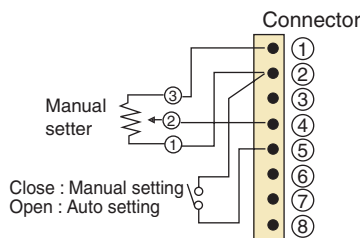

### • Auto/Manual setting selection (With gradient setter)

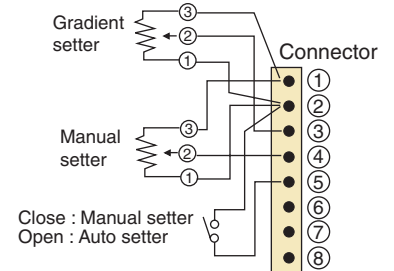

\* Gradient setting functions in both automatic and manual setting modes.

### • Manual setting (With manual setter)

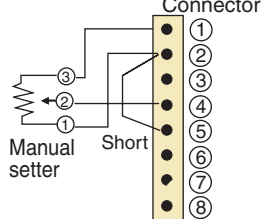

### • ON/OFF control

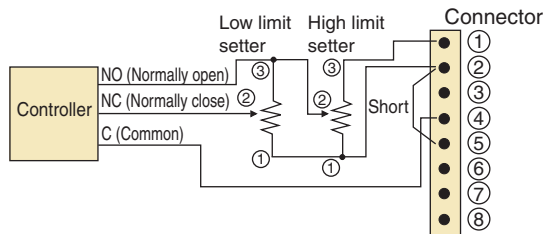

### • Heater break alarm output

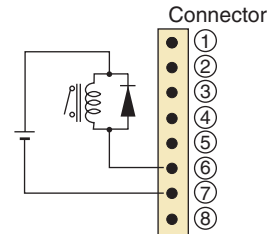

\* Connect a diode when a relay is used.

## Output setting selection

There are three output settings; input signal from a controller, external manual setting, and internal manual setting. Selection can be made via front keys for external contact action selection and external contact (connector Nos. 2-5).

External contact action selection	Close	Open
Only internal manual setting (Front key)	Internal manual setting	Internal manual setting
Internal manual setting (Front key) / Input signal	Internal manual setting	Input signal from controller
External manual setting (Front key) / Input signal	External manual setting	Input signal from controller

\* External contact is open when a connector is not used.

## Accessories

- Gradient setter, Manual setter, High/Low setter

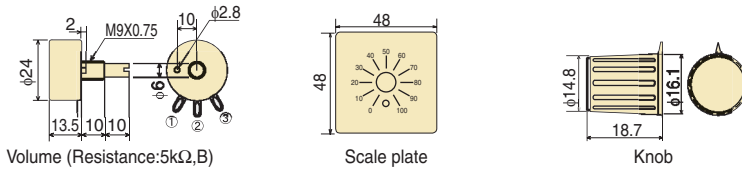

- Fuse unit

- 1 circuit type (For fast-blow fuse 1 piece)  
20A/30A/45A

Model Code	Specifications
THVP-F22	Holder + Fast-blow fuse (1 piece) for 20A
THVP-F32	Holder + Fast-blow fuse (1 piece) for 30A
THVP-F42	Holder + Fast-blow fuse (1 piece) for 45A
THVP-H02	Holder

- 60A/80A/100A

Model Code	Specifications
THVP-F62	Holder + Fast-blow fuse (1 piece) for 20A
THVP-F82	Holder + Fast-blow fuse (1 piece) for 30A
THVP-FA2	Holder + Fast-blow fuse (1 piece) for 45A
THVP-H03	Holder

- 3 circuits type (For fast-blow fuse 3 pieces)  
20A/30A

Model Code	Specifications
THVP-F21	Holder + Fast-blow fuse (1 piece) for 20A
THVP-F31	Holder + Fast-blow fuse (1 piece) for 30A
THVP-H01	Holder

\* Different rapid blown fuses are used for a single-circuit and three-circuit types even if load current rating is the same.

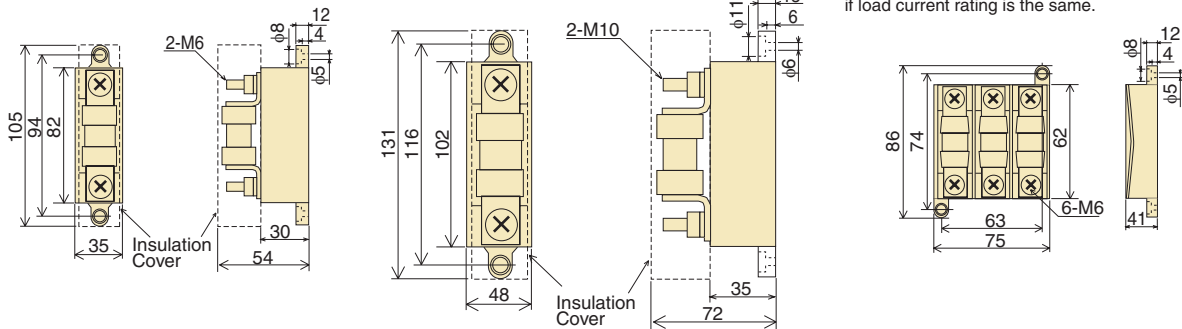

- Output voltmeter

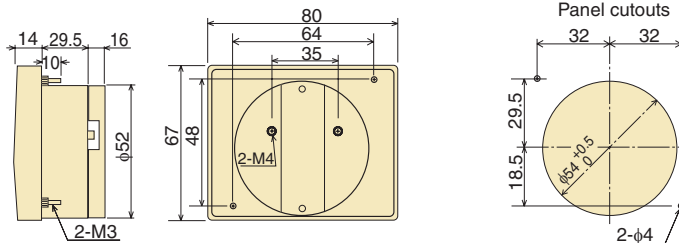

- Model code

\* Please refer to the following codes to order accessories.

Name		Model Code
Setter		THVP-S01
Output Voltmeter	150V span	THVP-V01
	300V span	THVP-V02
Connector (plug)		THVP-C01
Fuse unit	Fast blow fuse 1 piece + Holder for 3 circuits	20A THVP-F21
		30A THVP-F31
		45A THVP-F42
	Fast blow fuse 1 piece + Holder for 1 circuit	60A THVP-F62
		80A THVP-F82
		100A THVP-FA2
		20A THVP-F20
		30A THVP-F30

Name		Model Code
Fast blow fuse 3 circuits	20A	THVP-F20
	30A	THVP-F30
	45A	THVP-F45
Fast blow fuse 1 circuit	60A	THVP-F60
	80A	THVP-F80
	100A	THVP-FA0
	20,30A	THVP-H01
	20,30,45A	THVP-H02
Fuse holder	For 3 circuits	20,30,45A THVP-H01
	For 1 circuit	60,80,100A THVP-H03

\* Auxiliary parts are not in compliance with UL/CSA.



- Before operating this product, read the instruction manual carefully to avoid incorrect operation.
- This product is intended for use with industrial machines, test and measuring equipment. It is not designed for use with medical equipment.
- If it is possible that an accident may occur as a result of the failure of the product or some other abnormality, an appropriate independent protection device must be installed.
- When installing this product, avoid the following:
  - Direct exposure to sunlight. Direct contact with water.
  - Corrosive environments. Hazardous areas containing explosive or flammable gases.
  - Vibration or shock.
  - Areas subject to electrical noise caused by inductive interference, static electricity or magnetic fields.

### Caution for imitated products

As products imitating our product now appear on the market, be careful that you don't purchase these imitated products. We will not warrant such products nor bear the responsibility for any damage and/or accident caused by their use.

**RKC** RKC INSTRUMENT INC.  
(RIKA KOGYO CO.,LTD)

HEAD OFFICE : 16-6, KUGAHARA 5 CHOME OHTA-KU TOKYO 146-8515 JAPAN  
PHONE : 03-3751-9799 (+81 3 3751 9799)  
Email : info@rkinst.co.jp  
FAX : 03-3751-8585 (+81 3 3751 8585)  
http://www.rkinst.com/